

About this document

Content

This document is the fourth part of a series of application notes on the sound energy quantities *Sound Power* and *Sound Intensity*. It contains information on the determination of Sound Power on the basis of sound intensity measurements.

1. Determination of Sound Power from Sound Intensity _____ 1
2. Determination of Sound Intensity _____ 4
3. Measurement of the Particle Velocity _____ 4
4. Preparation of Sound Intensity Maps _____ 7
5. Facts that must be considered during the Measurements _____ 8

Target group

This document is intended for acousticians who are interested in the fundamentals of sound power determination from sound intensity.

Questions?

Do you have any questions? Your feedback is appreciated!

For questions on the content of this document: Imke.Hauswirth@head-acoustics.com

For technical questions on our products: SVP-Support@head-acoustics.com

Sound Power and Sound Intensity – Part 4

1. Determination of Sound Power from Sound Intensity

Sound power from sound intensity measurements

First, in order to determine the sound power from the sound intensity by means of the enveloping surface method, a measurement surface enveloping the source is defined. When selecting this surface, it must be ensured that there are no other sound sources or sound sinks within that surface.

In order to determine the sound energy penetrating this surface, the sound intensity perpendicular to the predefined measurement surface is determined at several points and spatially averaged over the surface. Two methods are available for spatial averaging: the continuous scanning method and the measurement at discrete points.

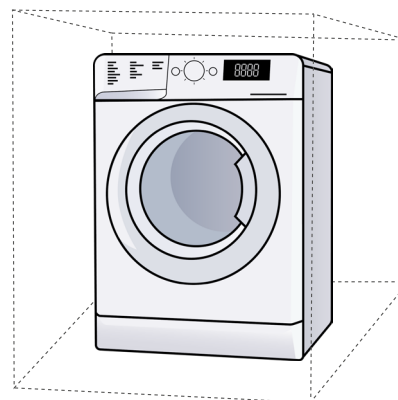

Scanning method

Scanning method

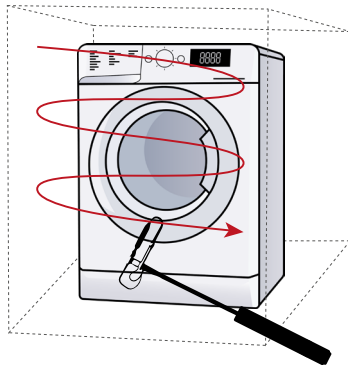

Figure 1: Sound intensity measurement with the scanning method

With the scanning method, the probe is moved in uniform loops over the measurement surface, as if painting the surface. The sound intensity is measured continuously, and the averaging time corresponds to the time needed to scan the surface. This results in an average sound intensity for the entire surface, from which the sound power for this surface can be calculated by multiplying it by the area of the measurement surface. Finally, the sound powers of all partial surfaces are added to obtain the total sound power. Details on the scanning method are described in the ISO 9614-2 and ISO 9614-3 standards.

Discrete-point method

Discrete-point method

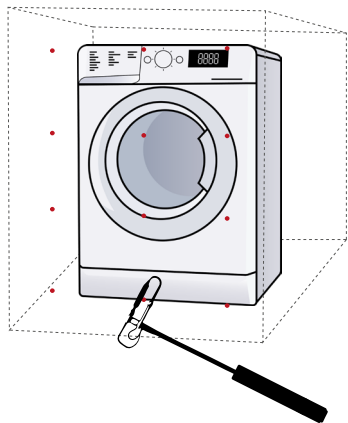

Figure 2: Sound intensity measurement at discrete points

When measuring at discrete points, the measurement surface is divided into small segments and the sound intensity is determined by one measurement per segment. For simplification, a measuring grid is usually manufactured from wire or string, which makes it easier to maintain the distance to the source and between the measuring points. The sound intensities of the individual measuring points are averaged and then multiplied by the surface to calculate the sound power for that surface. The total sound power is obtained by adding the partial amounts of all partial surfaces. Details on sound intensity measurement at discrete points are described in the ISO 9614-1 standard.

Advantages and disadvantages of the two measurement methods

The two methods have their different advantages and disadvantages. The question of which method is more appropriate depends on the application.

- Theoretically, the continuous method approximates the sound intensity more closely and therefore often provides the more accurate measurement results. However, a certain amount of experience is required to perform this method, e.g., to guide the probe at a constant speed while scanning the entire surface uniformly.
- The point-based method, on the other hand, is usually easier to implement and provides very repeatable results.

Consideration of background noise

Impact of background noise

One of the main advantages of the intensity method for sound power determination is that in this method stationary, incoherent background noise has no influence on the measurement result. In the intensity measurement, background noise will make a positive contribution on one side of the measurement object. However, since background noise will flow out of the measurement surface on the other side of the measurement object, the contribution on that side will be negative. Thus, when added up, the influence of the background noise will cancel out. Provided that the source of the background noise is not located within the measurement surface, integration over the entire enveloping surface theoretically completely eliminates the influence of the interfering background noise. Of course, this only applies if the background noise is relatively constant and does not change significantly over the measurement period.

Furthermore, the background noise must not be absorbed within the measurement surface, since otherwise the outflowing portion will be significantly smaller than the inflowing portion. Determining the sound power by means of sound pressure measurements cannot provide this compensation, since sound pressure is a scalar quantity. Only with the help of the vector quantity of sound intensity can the positive and negative components be distinguished.

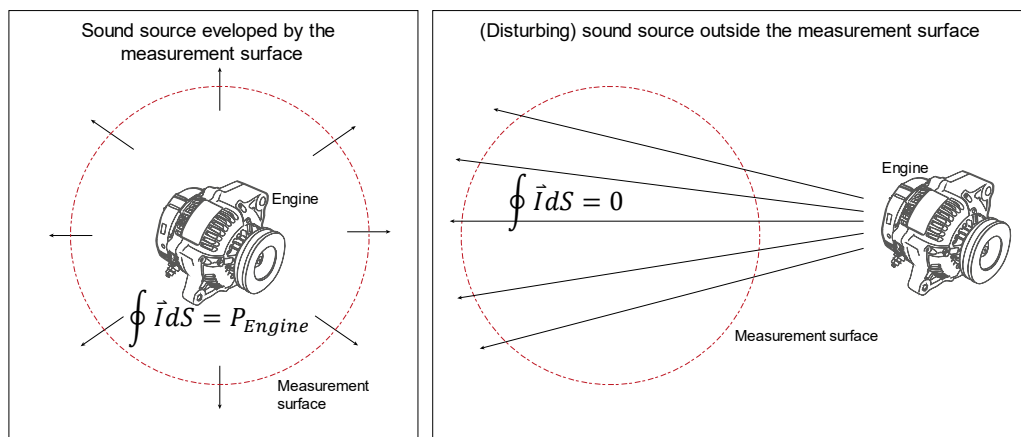

Figure 3: Sound source within and outside of the measurement surface

2. Determination of the Sound Intensity

Determination of the sound intensity

As a vector quantity, sound intensity contains both the magnitude and the direction of the energy flow. Usually, the sound intensity passing perpendicularly (i.e., at a 90° angle) through a surface is measured.

Direct measurement of the vector quantity sound intensity is not possible. Instead, it is determined indirectly by parallel recording of the sound pressure and the particle velocity.

Sound pressure and particle velocity

The sound intensity is the time-averaged energy flow per surface or sound power per surface. In the sound field of a plane wave, the sound intensity results from the product of the sound pressure and the particle velocity:

$$Power = \frac{Work}{Time}$$

$$Work = Force \cdot Distance$$

$$\frac{Distance}{Time} = Velocity$$

$$Intensity = \frac{Power}{Surface} = \frac{Work}{Surface \cdot Time} = \frac{Force}{Surface} \cdot \frac{Distance}{Time} = Pressure \cdot Velocity$$

$$\frac{Force}{Surface} = pressure$$

(This product of sound pressure and particle velocity gives the instantaneous sound intensity, which is averaged over time or the different measurement point to a single value.)

The sound pressure can easily be recorded by using an appropriate microphone. The measurement of the particle velocity is rather more complex (see next chapter).

3. Measurement of the Particle Velocity

PU probe

Two types of probes are available for measuring the particle velocity. First, the so-called PU probes that can be used to measure the sound pressure and the particle velocity directly. The velocity sensor consists of two very thin wires placed close to each other, which are heated by current flow. The difference in temperature at these wires caused by the particle velocity – combined with a change of the electrical resistance of the wires – provides the measurement signal of the particle velocity. A microphone is built into the probe to measure the sound pressure.

PP probe

Second, the pressure gradient probes, also called PP probes, which measure the sound pressure at two different points in the sound field using two microphones mounted close to each other. Linear approximation can be used to determine the pressure gradient from these two sound pressure values, which, in turn, is used to determine the particle velocity (see box on page 5).

Exercise: Determination of the Particle Velocity from the Pressure Gradient

The pressure gradient $\frac{\partial p}{\partial r}$ is a measure of the change in the current sound pressure over a distance. The pressure gradient can be approximated by linear approximation with two closely placed microphones:

$$\text{Pressure gradient} = \frac{\text{Sound pressure at point B} - \text{Sound pressure at point A}}{\text{Distance between point A and B}}$$

$$\Rightarrow \frac{\partial p}{\partial r} = \frac{p_B - p_A}{\Delta r}$$

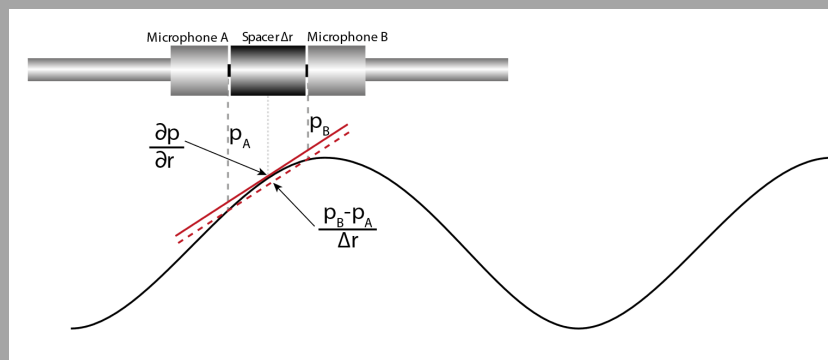

Figure 4: Approximation of the pressure gradient

By knowing the pressure gradient, the particle velocity can be determined using the Euler equation. The Euler equation is a mathematical model developed by Leonhard Euler to describe the flow of frictionless elastic fluids.

According to Euler, the velocity v for a medium with density ρ can be determined from the pressure gradient by integration:

$$v = -\frac{1}{\rho} \int \frac{\partial p}{\partial r} dt \Rightarrow \bar{v} = -\frac{1}{\rho} \int \frac{p_B - p_A}{\Delta r} dt$$

The calculated value applies for the center between point A and point B, i.e., the center between the two microphones. The sound pressure for this location is calculated by averaging the sound pressures at position A and B:

$$\bar{p} = \frac{p_A + p_B}{2}$$

The time-averaged product of particle velocity v and sound pressure p is the sound intensity I for the center between point A and B:

$$I = \bar{p} \cdot \bar{v}$$

$$\Rightarrow I = -\frac{p_B + p_A}{2\rho\Delta r} \int (p_B - p_A) dt$$

The sound intensity can be determined in the time domain as well as in the frequency domain.

The pair of microphones used must meet the highest standards for matching phase measurements so that the pressure gradient can be determined with sufficient accuracy. In addition, phase differences of the two microphones can be corrected by means of a phase calibration.

Directional characteristic of the PP probe

When measuring the sound intensity with a PP probe, the directional characteristic of the probe must be considered. Even if omnidirectional microphones are used with the probe, which record the sound pressure independently of direction, the sound intensity measured with the probe depends on the direction from which the sound arrives at the probe. This is due to the calculation method used and the design of the probe. In case of sound incidence from the 90° direction (in relation to the axis of the two microphones), the microphones simultaneously intercept the sound pressure fluctuations, thus there is no difference in pressure between the two microphones of the probe. Consequently, the calculated particle velocity is zero, as well as the sound intensity calculated from it. If the direction of sound incidence and the probe axis coincide (sound incidence from 0°), the full intensity is measured. For other sound incidence angles θ , the sound intensity will be reduced by the factor $\cos \theta$ compared to the sound incidence from 0°. For this reason, the directional characteristic of the PP sound intensity probe is also called *cosine characteristic*. The axis through the paired microphones is thus aligned in a way that it corresponds to the normal on the measurement surface.

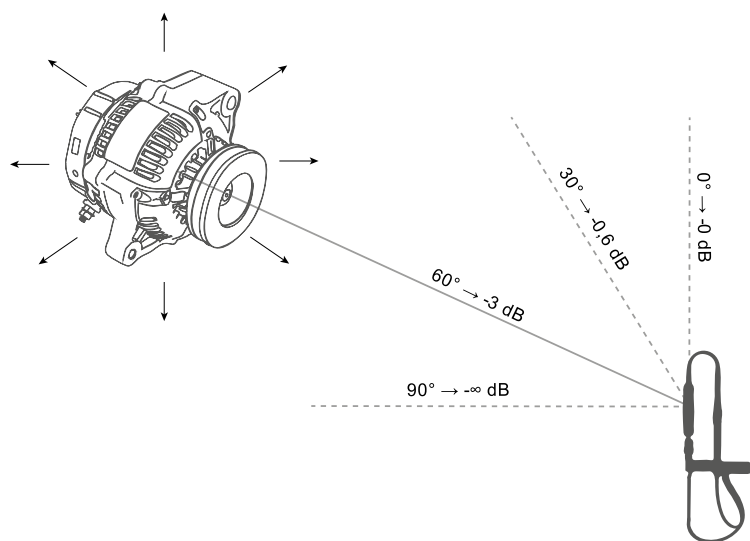

Figure 5: Directional characteristic of a PP probe

Spacer

In most PP probes, the microphones are aligned facing each other. They are separated from each other by a spacer. Usually, several spacers of different lengths are supplied with the probe. The spacer length influences the frequency range that can be recorded with the probe. The shorter the spacer, the higher the upper cut-off frequency and the longer the spacer, the lower the lower cut-off frequency. Figure 6 shows some reference values for usable frequency ranges of three different spacer lengths. The actual usable frequency range also depends on how well the phase responses of the two microphones are matched to each other. In addition, depending on its design, the frequency range may be enlarged (observe the manufacturer's specifications in the data sheet of the probe).

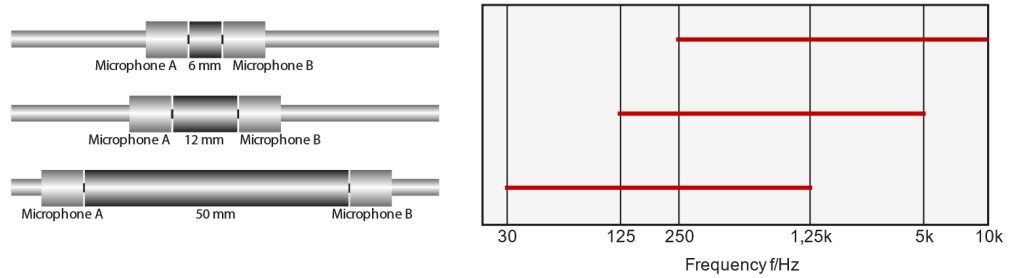

Figure 6: Usable frequency ranges depending on the separation of the microphones; accuracy +/-1dB

4. Preparation of Sound Intensity Maps

Targeted improvement of the emission characteristics

Examining the sound emission pattern of a complex machine and thus quantitatively determining the noise contribution of the individual components allows targeted improvement measurements to be taken. The time-consuming „trial & error“ method can thus be avoided, and instead the components making a high contribution to the overall emitted sound energy can be modified in a targeted manner. Measuring the sound intensity is a very suitable method for this purpose, as this can be carried out in-situ. If, instead, the sound pressure level of a single component of a machine were to be measured, the other components would have to be insulated, e.g., by encapsulation with soundproof material. This is hardly possible in some applications or makes the measurement very complex.

Sound intensity mapping

Thus, to reduce noise effectively, it is particularly important to localize and identify the sound sources. Sound intensity offers several options for this purpose. Using a sound intensity map, the different measured sound intensity values can be displayed on an image of the test object (e.g., coded as color).

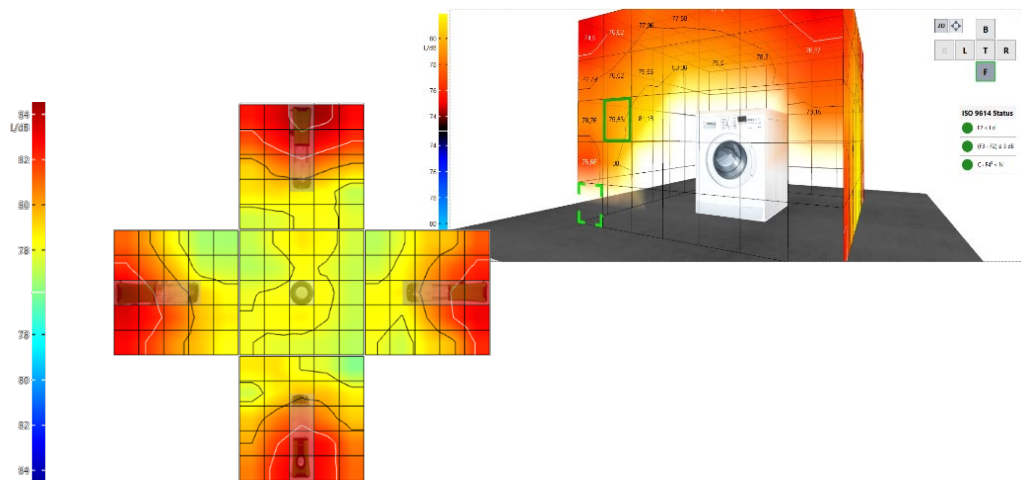

Figure 7: Sound intensity map of a blender and a washing machine

As with the sound intensity measurement for determining the sound power, a measurement grid can be used to measure the sound intensity at different equidistant points. The measurement values are stored and displayed as an overlay in an image

of the test object. By means of this visualization, the user can easily identify critical components and optimize them in a targeted manner. The intensity measurements can be performed in the near field, thus increasing the resolution and the signal-to-noise ratio.

5. Facts that must be considered during the measurements

Important notes

- Before measuring the sound intensity with a PP probe, a level and phase calibration of the probe microphones must be performed. Only in this way will the measurements provide useful results.
- To obtain meaningful results, the average time for the measurement of the sound intensity must be selected sufficiently long. Several measurements can be performed to check this. If the results of these measurements are comparable, the averaging time has been chosen sufficiently long. If this is not the case, the averaging time should be increased.
- For a correct determination of the sound power, the sound intensity probe must be aligned in a way that the axis of the microphones is perpendicular to the measurement surface.
- When using the scanning method, care must be taken to move the probe evenly and scan the entire surface. When measuring at discrete points, attention must be paid to ensure that an adequate number of points are measured.
- The number of measurement points is determined by the variability of the sound intensity over the measurement surface. The higher the variability, the more measurement points are required.
- The background noise must be sufficiently stationary. If possible, the background noise is to be measured while the actual test object is not in operation. This is how the contribution of the background noise can be investigated. The effect of the background noise can be minimized by reducing the measurement surface and measuring closer to the actual sound source.
- The length of the spacer affects the frequency range of the probe, and therefore must be adapted to the application. The shorter the spacer, the higher the upper cut-off frequency. The longer the spacer, the lower the lower cut-off frequency.



Proceed to the [third application note on sound power](#) providing information on the determination of sound power on the basis of sound pressure measurements.