

# VoCAS

Calibration and Equalization for Playback in VoCAS with DSB IV.1 and HMA V

# Application Note

Calibration and Equalization for Playback  
in VoCAS with DSB IV.1 and HMA V

Revision 1

## **Legal notices**

### **Copyright**

© HEAD acoustics GmbH 2024. All rights reserved. Subject to change.

All rights derived from this, also for partial use, are reserved by HEAD acoustics GmbH, Germany. Reproducing or distributing the manual or parts of it in any form is not allowed without express permission from HEAD acoustics GmbH.

All images are copyright to their respective owners.

### **Trademarks**

HEAD acoustics® is a registered trademark of HEAD acoustics GmbH.

RME is a registered trademark of RME Intelligent Audio Solutions.

AUDIX is a trademark of Audix Corporation.

Auratone is a trademark of Auratone LLC.

---

## Table of contents

1	Introduction .....	4
1.1	About VoCAS .....	4
1.2	Alternative equipment for VoCAS .....	4
1.3	Purpose .....	4
2	Requirements .....	5
2.1	Hardware .....	5
2.1.1	Applicable speakers .....	5
2.1.2	Third party hardware .....	5
2.2	Software .....	5
2.2.1	HEAD acoustics software .....	5
2.2.2	Third party software .....	5
2.3	Configuration for microphone calibration .....	5
2.4	Configuration for mouth equalization at MRP of HMS II.5 .....	6
2.5	Configuration for loudspeaker equalization (exemplary) .....	7
2.6	HFRP calibration at DUT microphone (exemplary) .....	8
2.7	Configuration for playback via HMS II.5 (exemplary) .....	9
2.8	Configuration for playback via loudspeaker (exemplary) .....	10
3	Microphone calibration .....	11
3.1	Preparation .....	11
3.2	Calibration procedure .....	11
4	Loudspeaker / mouth equalization .....	17
4.1	Preparation .....	17
4.2	Microphone position for equalization .....	17
4.2.1	MRP at HMS II series .....	17
4.2.2	MRP at artificial mouth .....	19
4.2.3	Far-field equalization with loudspeaker .....	20
4.3	Equalization procedure .....	20
5	HFRP Calibration .....	26
5.1	General .....	26
5.2	Example for HFRP calibration .....	26
5.3	Preparation .....	27
5.4	HFRP calibration procedure .....	27

# 1 Introduction

## 1.1 About VoCAS

VoCAS is a test software for speech recognition evaluation. It supports the optimization and benchmarking of any device incorporating speech signal processing and speech recognition.

Speech recognition systems are an essential component of voice-controlled IoT devices such as smart speakers, smartphones, tablets, and multimedia systems in vehicles. VoCAS helps evaluating the speech recognition quality of appropriate devices in complex scenarios realistically and objectively. The software considers all factors that significantly influence the quality of speech recognition systems: the acoustic environment, background noise, different talkers, and different languages or accents. Thus, with the help of reproducible test sequences adapted to the respective applications, manufacturers receive essential information for optimizing their speech recognition systems.

## 1.2 Alternative equipment for VoCAS

The primarily recommended hardware equipment for VoCAS is an artificial head from the HMS series together with the hardware platform *labCORE*. Alternatively, HEAD acoustics provides convenient equipment to use VoCAS without having to acquire the most sophisticated hardware for the application. For this purpose, VoCAS supports the DSB IV.1 audio system in combination with the HMA V amplifier, an appropriate measurement microphone, and a loudspeaker/artificial mouth.

## 1.3 Purpose

This document helps users with establishing a measurement configuration including the aforementioned alternative equipment. All necessary equipment is listed and illustrated in block diagrams of exemplary application configurations. The procedures of microphone calibration, loudspeaker equalization, and HFRP calibration are described in detail consecutively. After executing these procedures, VoCAS is ready for playing back audio files via the applied configuration.

## 2 Requirements

### 2.1 Hardware

#### 2.1.1 Applicable speakers

One of the following:

- HMS II.5 (or any other HEAD measurement system containing an artificial mouth)
- Standalone artificial mouth without amplifier
- Loudspeaker

#### 2.1.2 Third party hardware

- DSB IV.1 (RME Fireface UCX II)
- HMA V (Auratone A2-30)
- Audix TM-1 or equivalent measurement microphone with XLR connector
- Calibrator / Pistonphone
- PC
- Microphone stand (depending on use case and/or speaker)

### 2.2 Software

#### 2.2.1 HEAD acoustics software

- VoCAS Core

#### 2.2.2 Third party software

- RME TotalMix FX
- Driver for RME Fireface UCX II

### 2.3 Configuration for microphone calibration

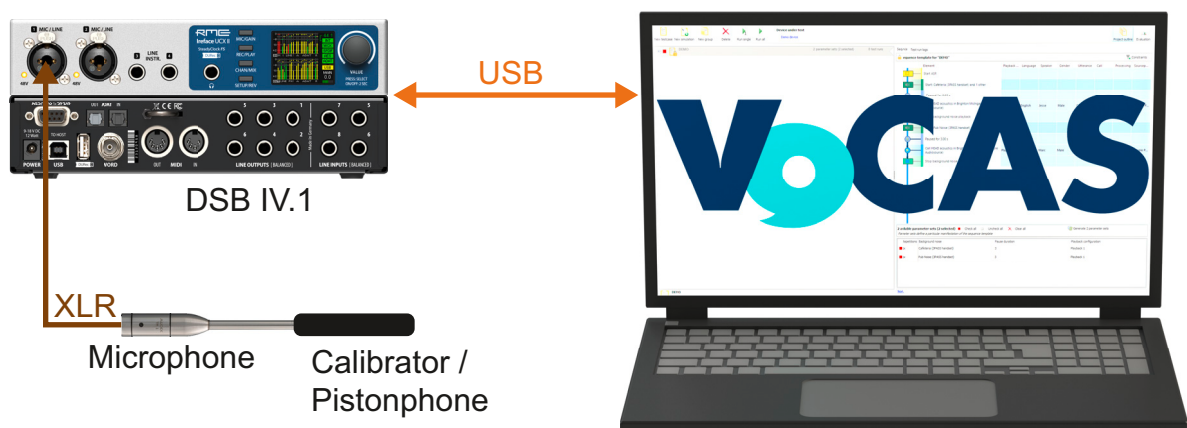

1. Connect the PC to DSB IV.1 by USB cable.
2. Connect microphone to DSB IV.1 by XLR cable.
3. Attach the calibrator/pistonphone to the microphone.

## 2.4 Configuration for mouth equalization at MRP of HMS II.5

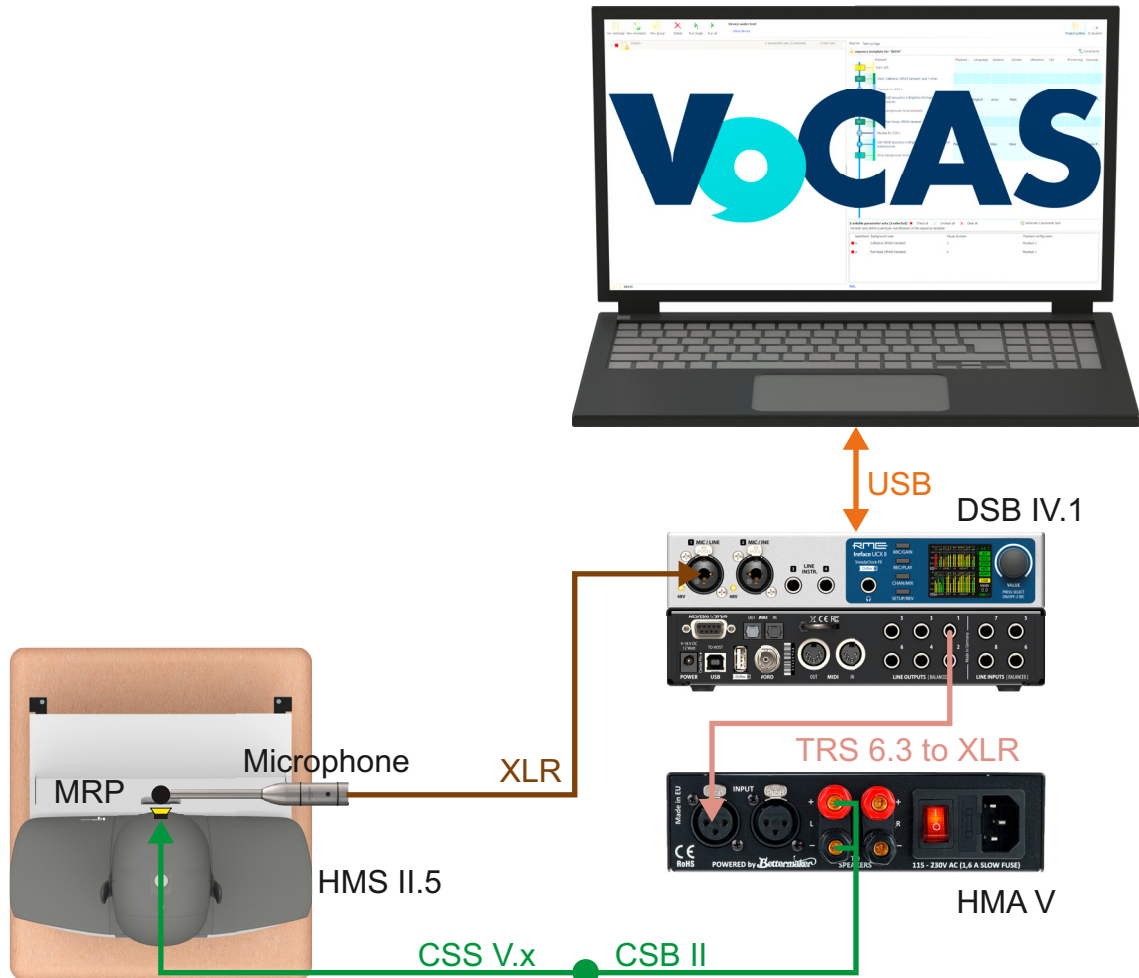

1. Connect the PC to DSB IV.1 by USB cable.
2. Connect the microphone to DSB IV.1 by XLR cable.
3. Connect DSB IV.1 to HMA V by 6.3 TRS ↔ XLR cable.
4. Connect HMA V to CSB II cable.
5. Connect CSB II cable to CSS V.x cable.
6. Connect HMS II.5 to CSS V.x cable.

## 2.5 Configuration for loudspeaker equalization (exemplary)

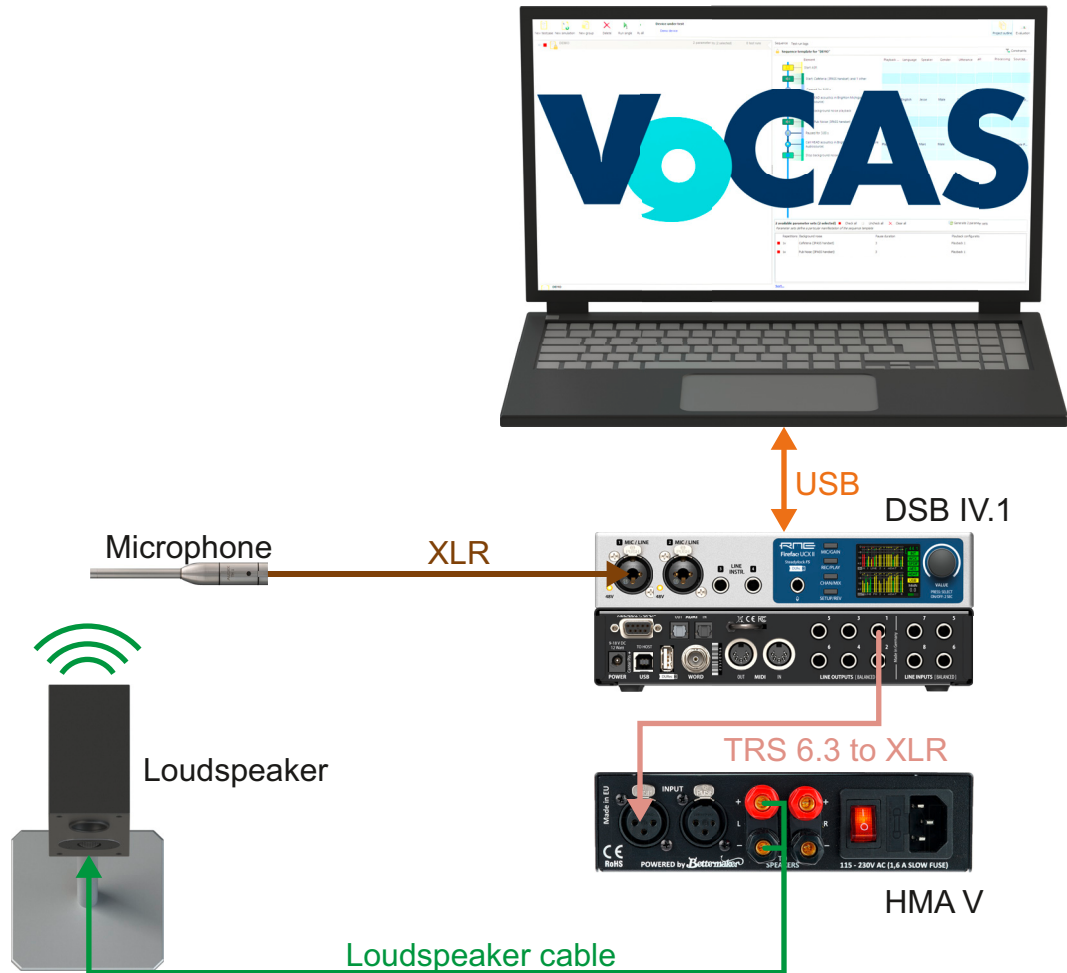

1. Connect the PC to DSB IV.1 by USB cable.
2. Connect the microphone to DSB IV.1 by XLR cable.
3. Connect DSB IV.1 to HMA V by 6.3 TRS ↔ XLR cable.
4. Connect HMA V to the loudspeaker by an appropriate loudspeaker cable.



## 2.6 HFRP calibration at DUT microphone (exemplary)

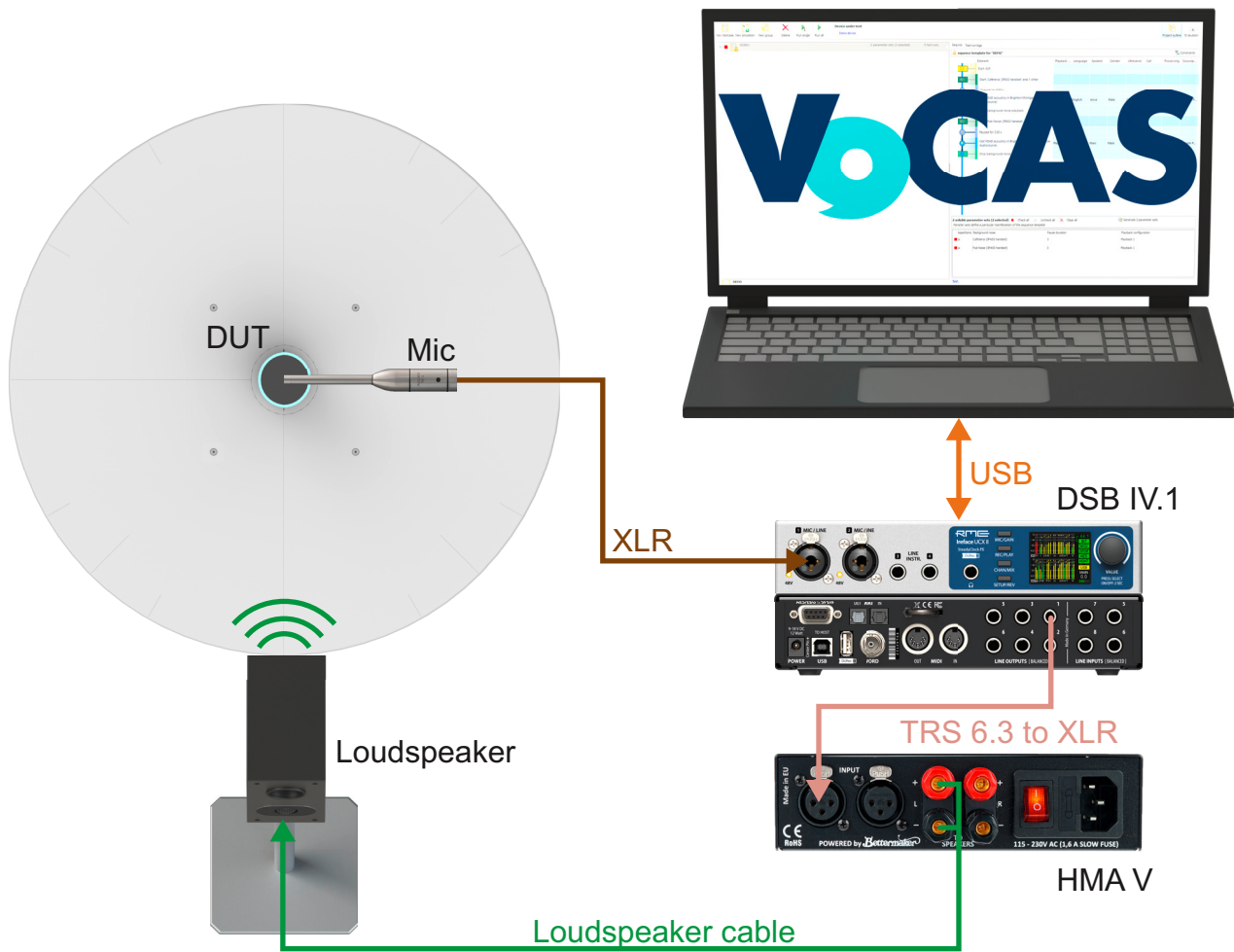

1. Connect the PC to DSB IV.1 by USB cable.
2. Connect the microphone to DSB IV.1 by XLR cable.
3. Connect DSB IV.1 to HMA V by 6.3 TRS ↔ XLR cable.
4. Connect HMA V to the loudspeaker by an appropriate loudspeaker cable.

## 2.7 Configuration for playback via HMS II.5 (exemplary)

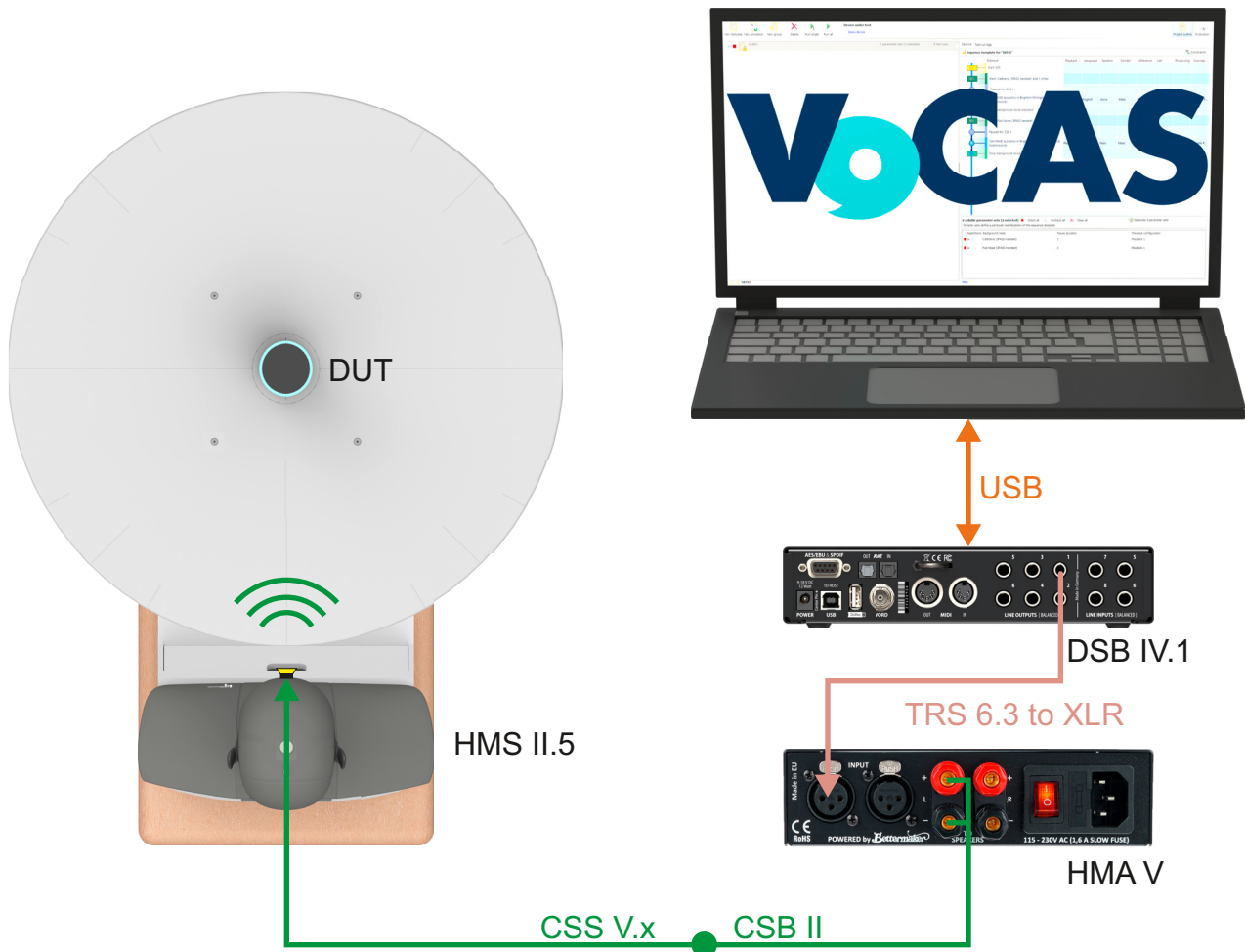

1. Connect the PC to DSB IV.1 by USB cable.
2. Connect DSB IV.1 to HMA V by 6.3 TRS ↔ XLR cable.
3. Connect HMA V to CSB II cable.
4. Connect CSB II cable to CSS V.x cable.
5. Connect HMS II.5 to CSS V.x cable.

## 2.8 Configuration for playback via loudspeaker (exemplary)

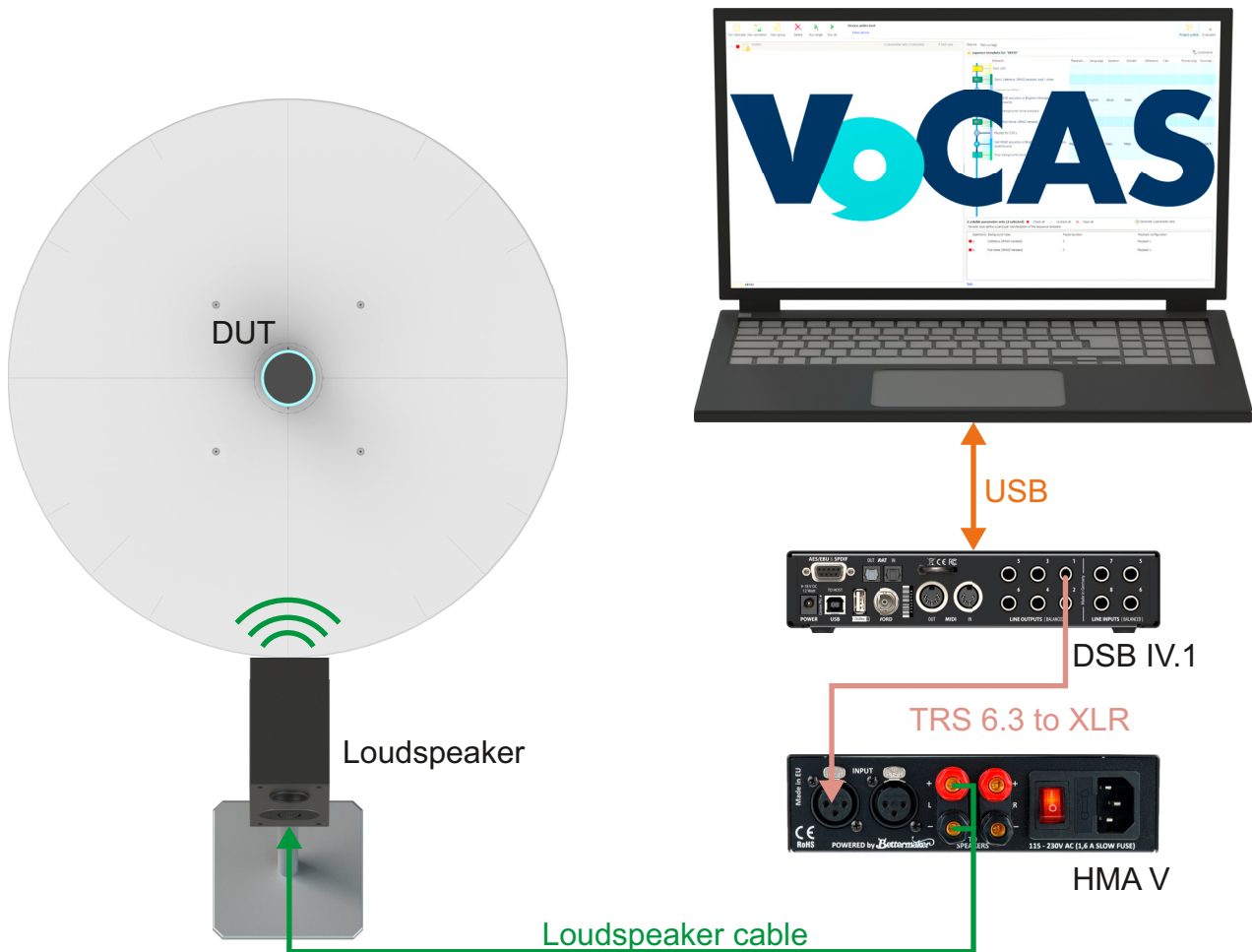

1. Connect the PC to DSB IV.1 by USB cable.
2. Connect DSB IV.1 to HMA V by 6.3 TRS ↔ XLR cable.
3. Connect HMA V to the loudspeaker by an appropriate loudspeaker cable.

## 3 Microphone calibration

### 3.1 Preparation

- Connect the equipment according to chapter 2.3.
- Start RME TotalMix FX.
- Start VoCAS.

### 3.2 Calibration procedure

1. Go to RME TotalMix FX.
2. Select **Options** in the menu bar.
3. Select **Reset Mix**.
4. Select **Total Reset**.

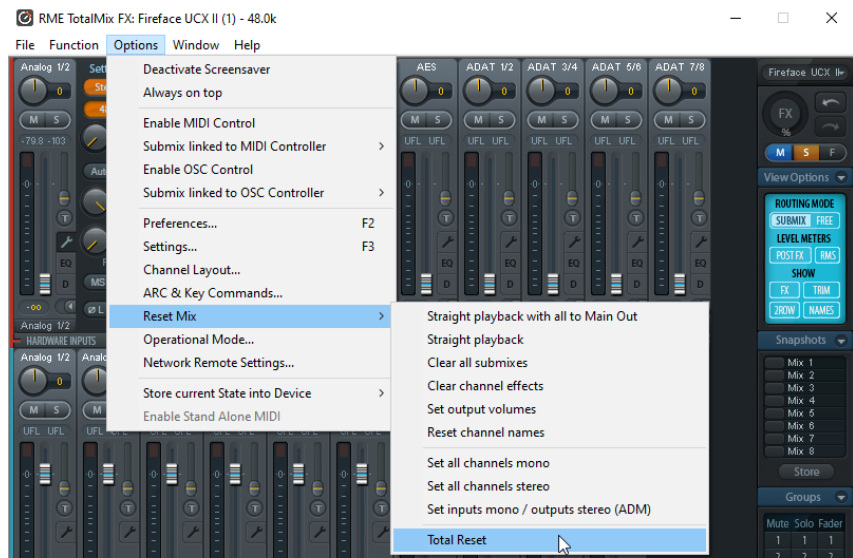

5. Enable phantom supply for the connected microphone. Select the button **48 V**. The color of the button changes to orange.



6. Go to VoCAS.
7. Select File > VoCAS settings.
8. Select Audio > Hardware configuration.
9. Select Input.
10. Select Fireface UCX II.
11. Select Microphone 1.
12. Select **None**.

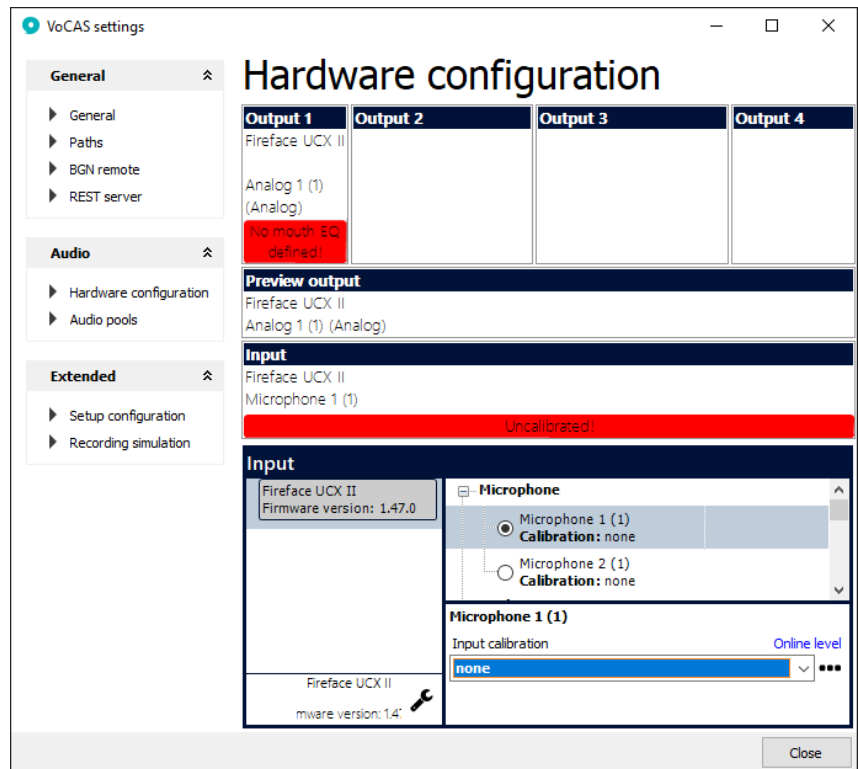

13. Select **Acoustical** as kind of calibration.
14. Select **Next**.

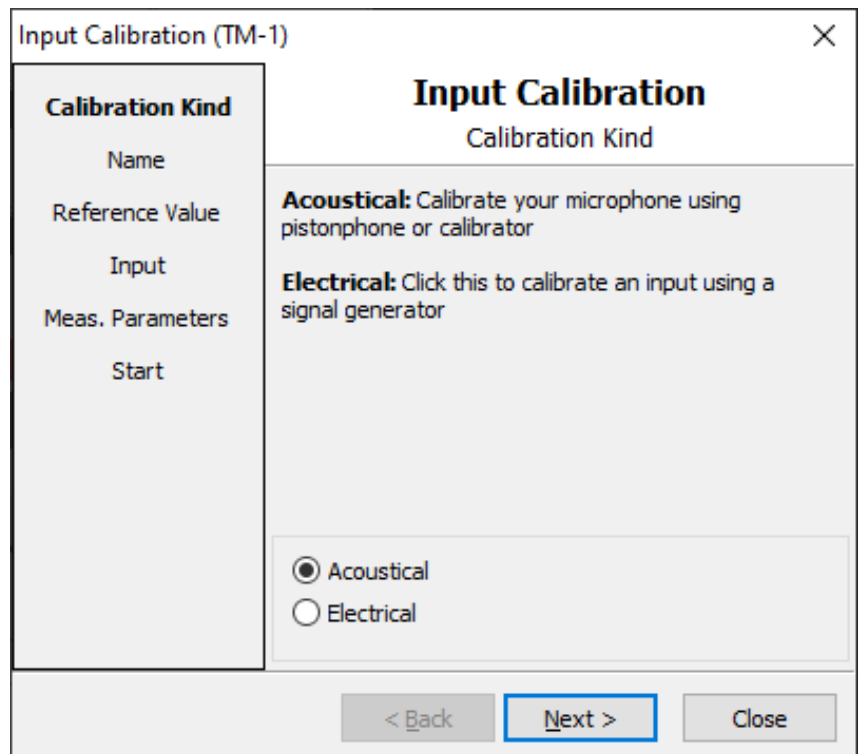

15. Select  to create a new input calibration.

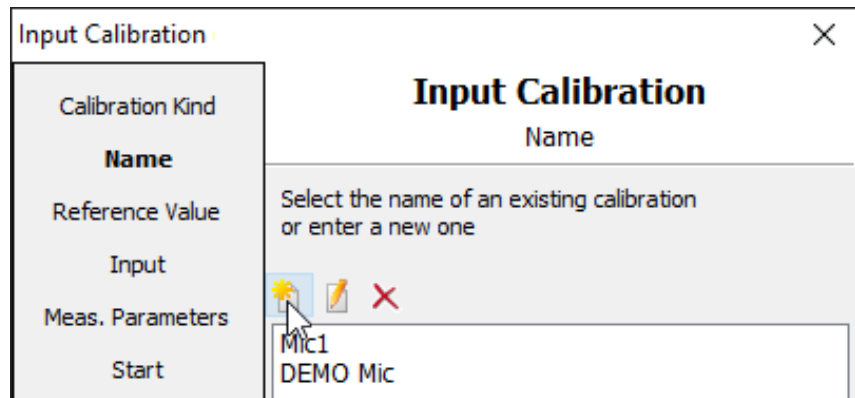

16. Enter technical specifications of the microphone.

17. Select **OK**.

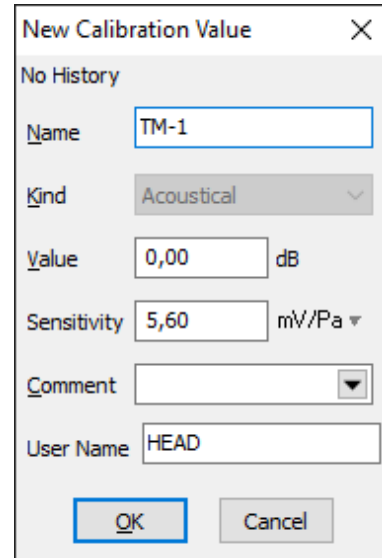

18. Highlight the specified microphone.

19. Select **Next**.

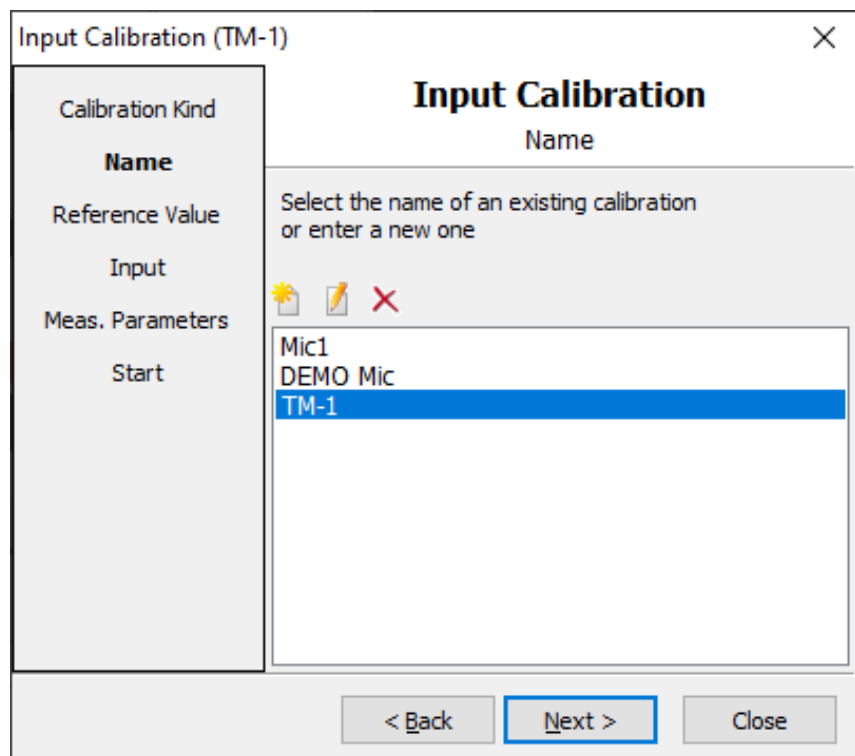

20. Enter the output level of the calibrator/pistonphone.
21. Select **Next**.

**Input Calibration (TM-1)** [Close]

**Input Calibration**  
Reference Value

Calibration Kind  
Name  
**Reference Value**  
Input  
Meas. Parameters  
Start

Enter the output level of your calibrator/pistonphone

dB[SPL] ▾

< Back   **Next >**   Close

22. Select **Fireface UCX II**.
23. Select the applied input interface.
24. Select the applied channel.
25. Select **Next**.

**Input Calibration (TM-1)** [Close]

**Input Calibration**  
Input

Calibration Kind  
Name  
Reference Value  
**Input**  
Meas. Parameters  
Start

Select the input where your sensor is connected

Frontend  
 Fireface UCX II   Show configuration

Input  
Microphone ▾

Channel  
 Microphone 1 (1)    Microphone 2 (1)

< Back   **Next >**   Close

26. Select the duration of the calibration measurement. Usually 1000 ms are sufficient. 2000 ms are recommended.
27. Select **Next**.

**Input Calibration (TM-1)**

**Input Calibration**  
Measurement Parameters

**Duration:** Length of the measurement

**Generate Signal:** Generate output signal with selected frequency and level during calibration

**Generate Signal**

Duration  ms

< Back   **Next >**   Close

28. Check and confirm the settings for the calibration. Make sure that the calibrator/pistonphone is properly attached to the microphone.
29. Select **Start** to execute the calibration.

**Input Calibration (TM-1)**

**Input Calibration**  
Start

Prev. calibration: Not done  
New calibration: Not done

Name	<b>TM-1</b>
Kind	Acoustical
Ref. value	94,00 dB[SPL]
Sensitivity	6 mV/Pa (nominal)
Channel	Microphone 1 (1)

< Back   **Start**   Close



30. The calibration runs. Its progress is indicated by the progress bar.

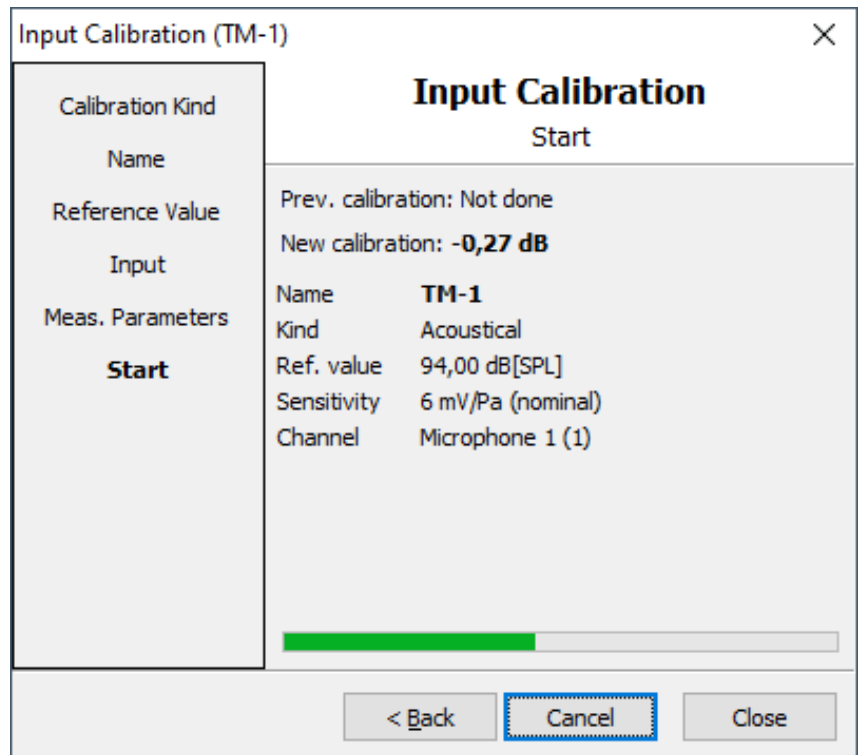

31. VoCAS presents the calibration value and the spectrum of the calibration.

32. Select **Close** after successful calibration.

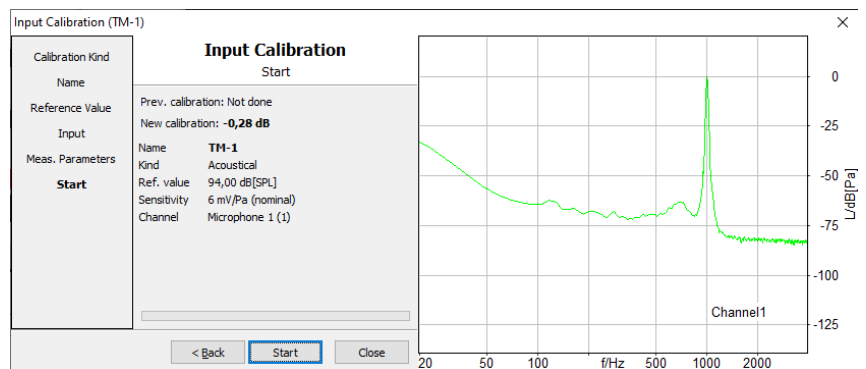

## 4 Loudspeaker / mouth equalization

### 4.1 Preparation

- If necessary, run or repeat the microphone calibration. Refer to chapter 3.
- Connect the equipment according to chapter 2.4 or chapter 2.5.
- If a certain level is required at the microphone of the device under test (hands-free device), please refer to chapter 5 for HFRP (hands-free reference point) calibration after successful equalization.
- Start RME TotalMix FX.
- Start VoCAS.

### 4.2 Microphone position for equalization

#### 4.2.1 MRP at HMS II series

1. Assemble lip ring and MRP pointer.

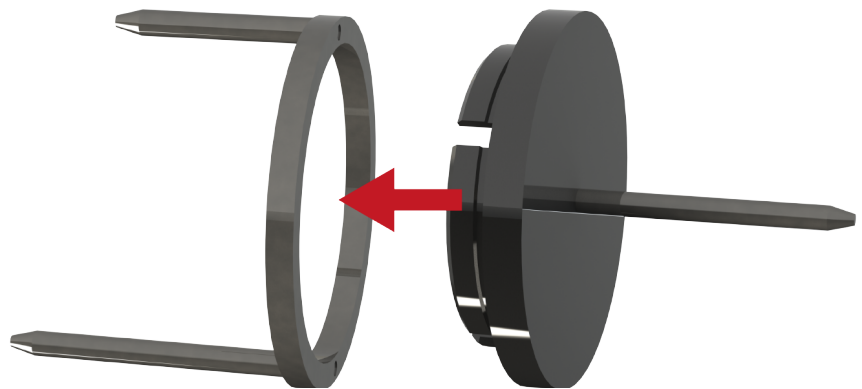

2. Attach the assembly of lip ring and MRP pointer to HMS II.
3. Attach the lip ring to the holes above and below the artificial mouth. The longer bolt belongs in the hole below the mouth.

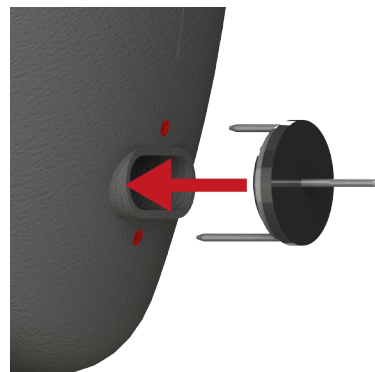

4. Remove the cover from the snap lock at the throat.

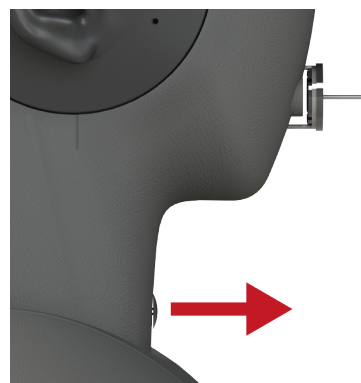

5. Prepare the microphone holder with the rubber bands according to the length of the applied microphone. Hook the rubber bands into the notches of the rods.



6. Carefully insert the microphone holder into the snap lock at the throat. The rods of the microphone holder face downwards. It locks with a significant sound.

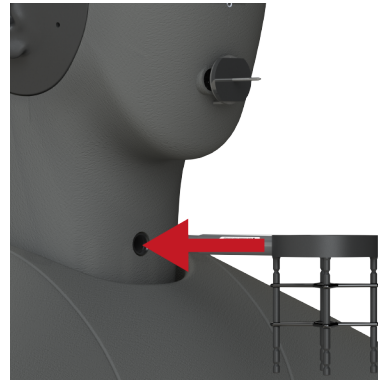

7. Insert the microphone from the bottom through the center of the rubber bands. The rubber bands fixate the position of the microphone.

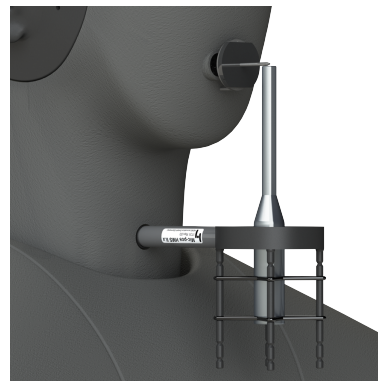

8. Position the microphone that its center is right below the tip of the MRP pointer.



9. Remove the MRP pointer and the lip ring carefully. Do not change the position of the microphone anymore.
10. Go to chapter 4.3.

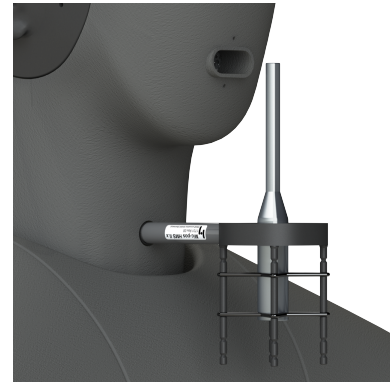

#### 4.2.2 MRP at artificial mouth

1. Assemble the microphone to a microphone stand.
2. Position the microphone tip at the MRP.
3. Go to chapter 4.3.

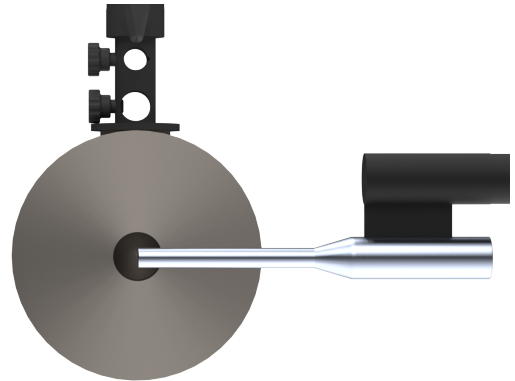
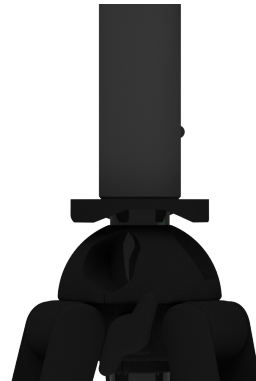

### 4.2.3 Far-field equalization with loudspeaker

1. Assemble the microphone to a microphone stand.
2. Position the microphone at the desired position for the far-field equalization.  
The minimum distance between microphone and loudspeaker should equal the diameter of the woofer. Further, the distance between microphone and loudspeaker depends on the loudspeaker size in relation to the dimension of the room.
3. Go to chapter 4.3.



### 4.3 Equalization procedure

4. Go to RME TotalMix FX.
5. Select **Options** in the menu bar.
6. Select **Reset Mix**.
7. Select **Total Reset**.

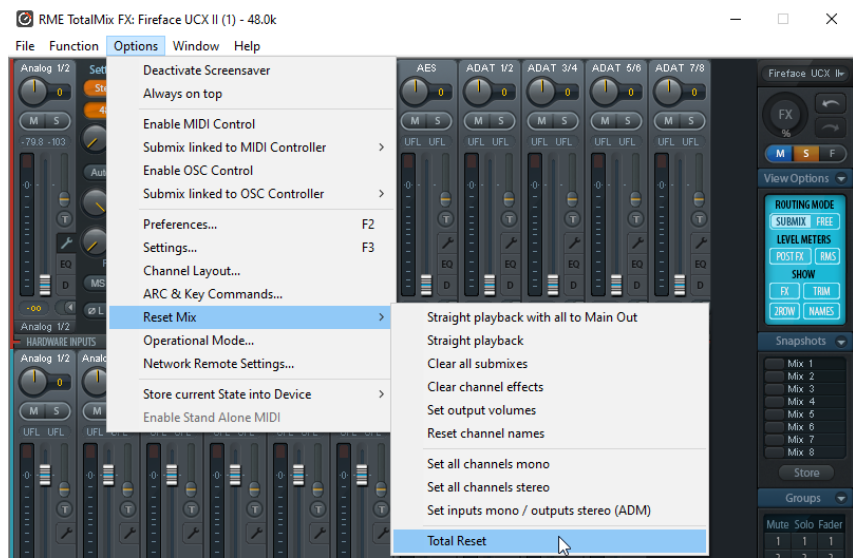

8. Enable phantom supply for the connected microphone.  
Select the button **48 V**. The color of the button changes to orange.



9. Go to VoCAS.
10. Select File > VoCAS settings.
11. Select Audio > Hardware configuration.
12. Select Output.
13. Select Fireface UCX II.
14. Select Analog 1.
15. Select .

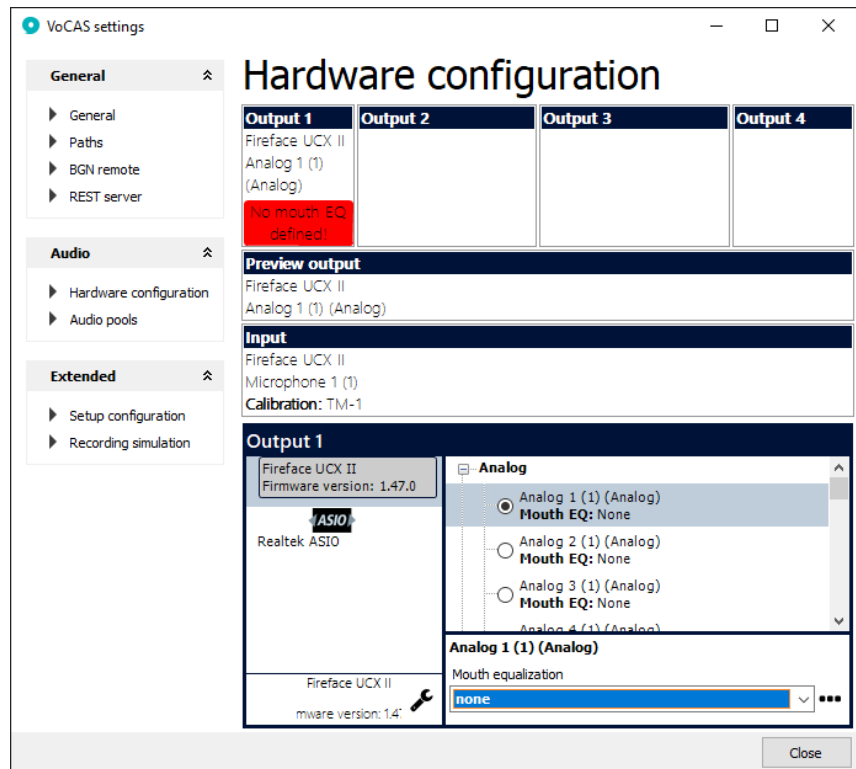

16. Create new equalization set by selecting .

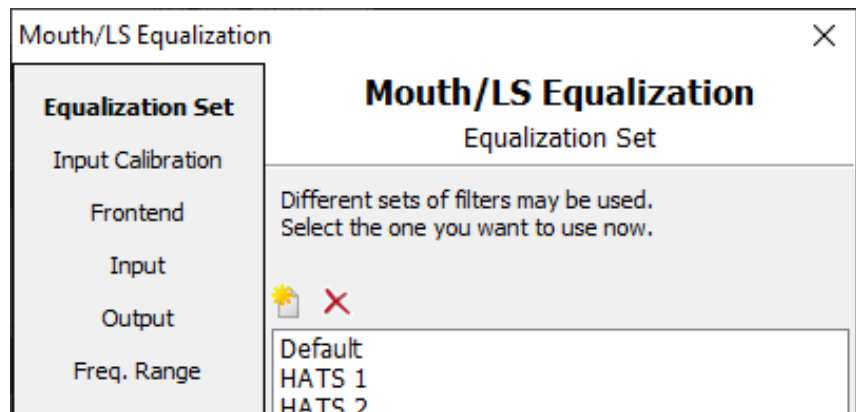

17. Enter a name for the equalization set.
18. Select **Ok**.
19. Highlight the created equalization set.
20. Select **Next**.

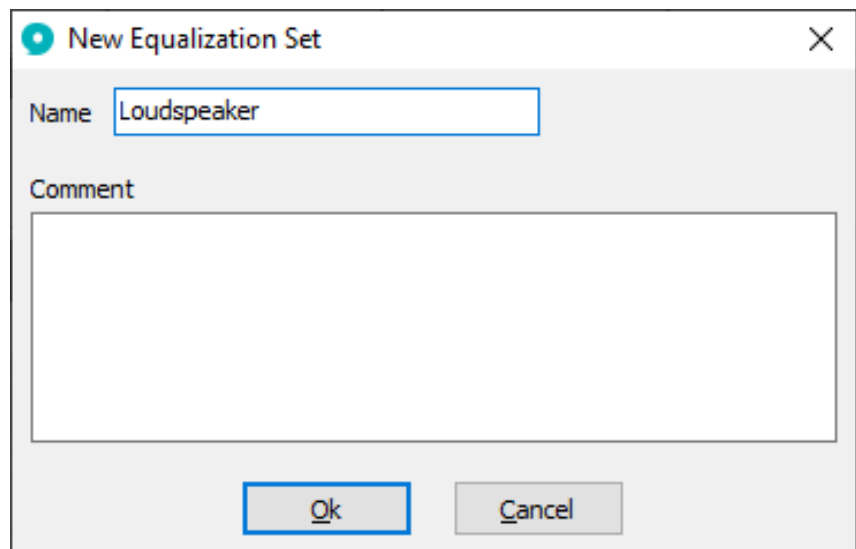

21. Select the appropriate microphone calibration.
22. Select **Next**.

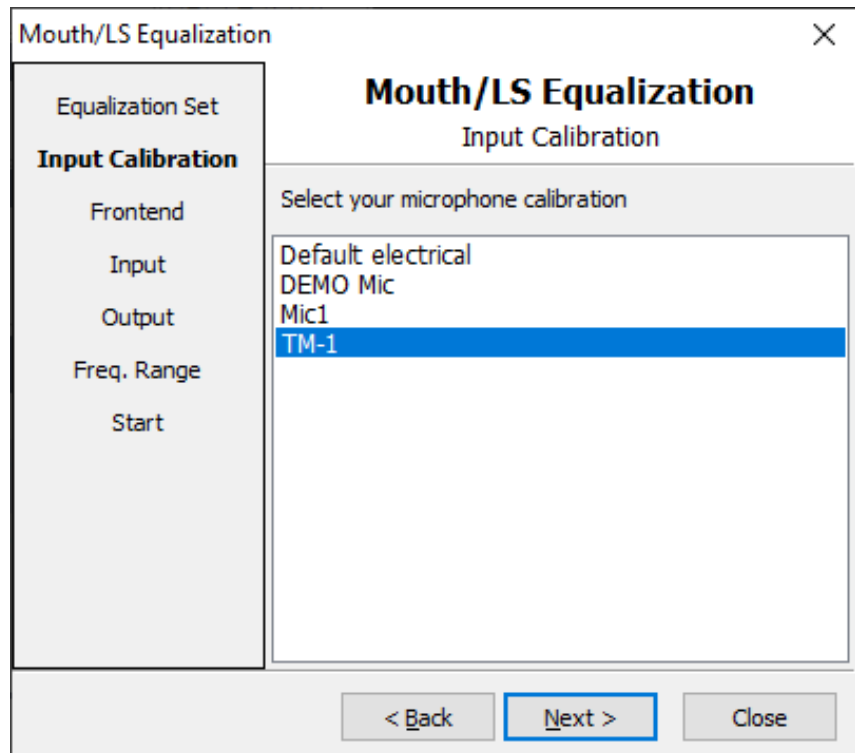

23. Select **Fireface UCX II**.
24. Select **Next**.

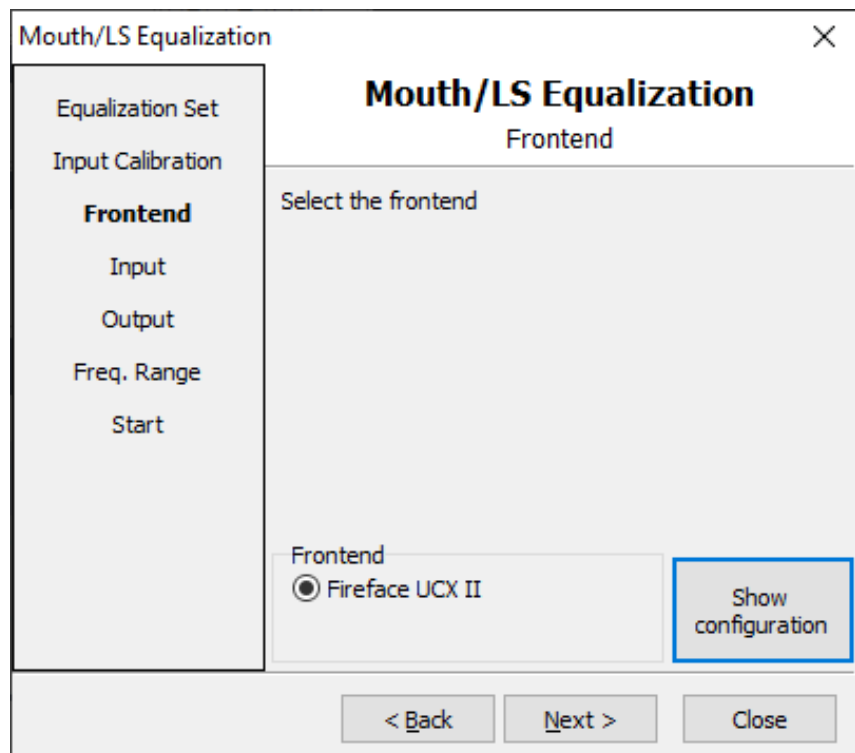

25. Select the applied input interface and the applied channel of the microphone.
26. Select **Next**.

The screenshot shows the 'Mouth/LS Equalization' dialog box with the 'Input' tab selected. The left sidebar contains a list of options: Equalization Set, Input Calibration, Frontend, **Input**, Output, Freq. Range, and Start. The main area is titled 'Mouth/LS Equalization Input' and contains the instruction 'Select the input where your microphone is connected'. Below this, there is an 'Input' dropdown menu set to 'Microphone'. Under 'Input Channel', there are two radio buttons: 'Microphone 1 (1)' (which is selected) and 'Microphone 2 (1)'. At the bottom, there are three buttons: '< Back', 'Next >' (highlighted with a blue border), and 'Close'.

27. Select the applied output interface and the applied channel of the loudspeaker/artificial mouth.
28. Optional:  
Enter the gain of the external amplifier. Usually, it is recommended to apply the default setting of the HMA V amplifier. A positive value will attenuate the level of the playback during the equalization by the entered value. A negative value increases the level of the playback during the equalization by the entered value.
29. Select **Next**.

The screenshot shows the 'Mouth/LS Equalization' dialog box with the 'Output' tab selected. The left sidebar contains a list of options: Equalization Set, Input Calibration, Frontend, Input, **Output**, Freq. Range, and Start. The main area is titled 'Mouth/LS Equalization Output' and contains the instruction 'Select the output where your speaker/mouth is connected'. Below this, there is an 'Output' dropdown menu set to 'Analog'. Under 'Output Channel', there are six radio buttons: 'Analog 1' (selected), 'Analog 3', 'Analog 5', 'Analog 2', 'Analog 4', and 'Analog 6'. Under 'Gain of External Amplifier', there is a text input field containing '0,0' followed by 'dB'. At the bottom, there are three buttons: '< Back', 'Next >' (highlighted with a blue border), and 'Close'.



## 30. Optional:

Enter the expected attenuation of the signal if the microphone is not positioned at the MRP.

Recommended attenuations for the distances of 0.3 m and 0.5 m are provided. VoCAS adjusts the playback level during equalization accordingly.

The attenuation is set to 0 dB (MRP) by default.

31. Enter the desired frequency range of the equalization. Common frequency ranges are provided in **Common Ranges**.32. Select **Next**.

The screenshot shows the 'Mouth/LS Equalization' dialog box with the 'Frequency Range' step selected in the left sidebar. The main area is titled 'Mouth/LS Equalization' and 'Frequency Range'. It contains the instruction 'Enter the frequency limits for the equalization'. Under 'Attenuation', there is a text input field with '19,6', a 'dB' label, an 'MRP' button, a '0.3m' button (highlighted with a blue border), and a '0.5m' button. Under 'Frequency Range', there are two text input fields with '200' and '9000', followed by 'Hz' and a blue link labeled 'Common Ranges'. At the bottom, there are three buttons: '< Back', 'Next >', and 'Close'.

## 33. Check and confirm the settings for the equalization.

34. Select **Start** to execute the equalization.

## 35. The equalization runs. Its progress is indicated by a progress bar.

The screenshot shows the 'Mouth/LS Equalization' dialog box with the 'Start' step selected in the left sidebar. The main area is titled 'Mouth/LS Equalization' and 'Start'. It contains the text 'Prev. equalization: Not done'. Below this is a table with the following settings:

Input Calibration	TM-1 (-1,0 dB)
Frontend	Fireface UCX II
Input Channel	Microphone 1 (1)
Input	Microphone
Output Channel	Channel 1
Output	Analog
Freq. Range	200...9000 Hz

Below the table is a progress bar. At the bottom, there are three buttons: '< Back', 'Start' (highlighted with a blue border), and 'Close'.

36. VoCAS presents the result of the equalization after executing the measurements. The equalization has been successful if the curve lies within the specified limits of the tolerance scheme.

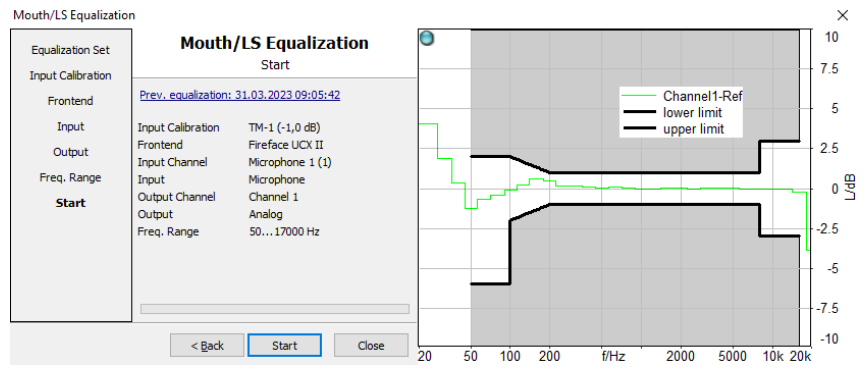

## 5 HFRP Calibration

### 5.1 General

The hands-free reference point (HFRP) is located on the axis of the loudspeaker, at a certain distance from the loudspeaker in free-field. The HFRP calibration determines the correction value to achieve a desired level at the microphone position of the device under test. The correction value from the HFRP calibration will be applied during playback with VoCAS. Thus, VoCAS adjusts the level of playback to generate a determined level at the DUT microphone.

### 5.2 Example for HFRP calibration

- After successful equalization, the output level of the mouth / speaker shall be  $0 \text{ dB}_{\text{Pa}} = 94 \text{ dB}_{\text{SPL}}$ .
- The measurement microphone is as close as possible to the position of the DUT microphone.
- In the HFRP calibration, VoCAS expects the nominal level of the playback at the HFRP according to the expected attenuation. E.g., expected attenuation =  $24 \text{ dB} \rightarrow 94 \text{ dB}_{\text{SPL}} - 24 \text{ dB} = 70 \text{ dB}_{\text{SPL}}$ . The nominal level is  $70 \text{ dB}_{\text{SPL}}$ .
- VoCAS plays back a signal at the mouth/loudspeaker, records it at the HFRP, and determines the actual level. The deviation between actual level and nominal level is saved as correction value. For playback, VoCAS increases or decreases the playback level by this value. Thus, the HFRP correction value ensures a signal level of  $70 \text{ dB}_{\text{SPL}}$  at the DUT microphone which is located at the HFRP.
- For changing the distance between mouth/speaker and measurement/DUT microphone but keeping the same level at the microphone, the HFRP calibration has to be repeated for the new distance.

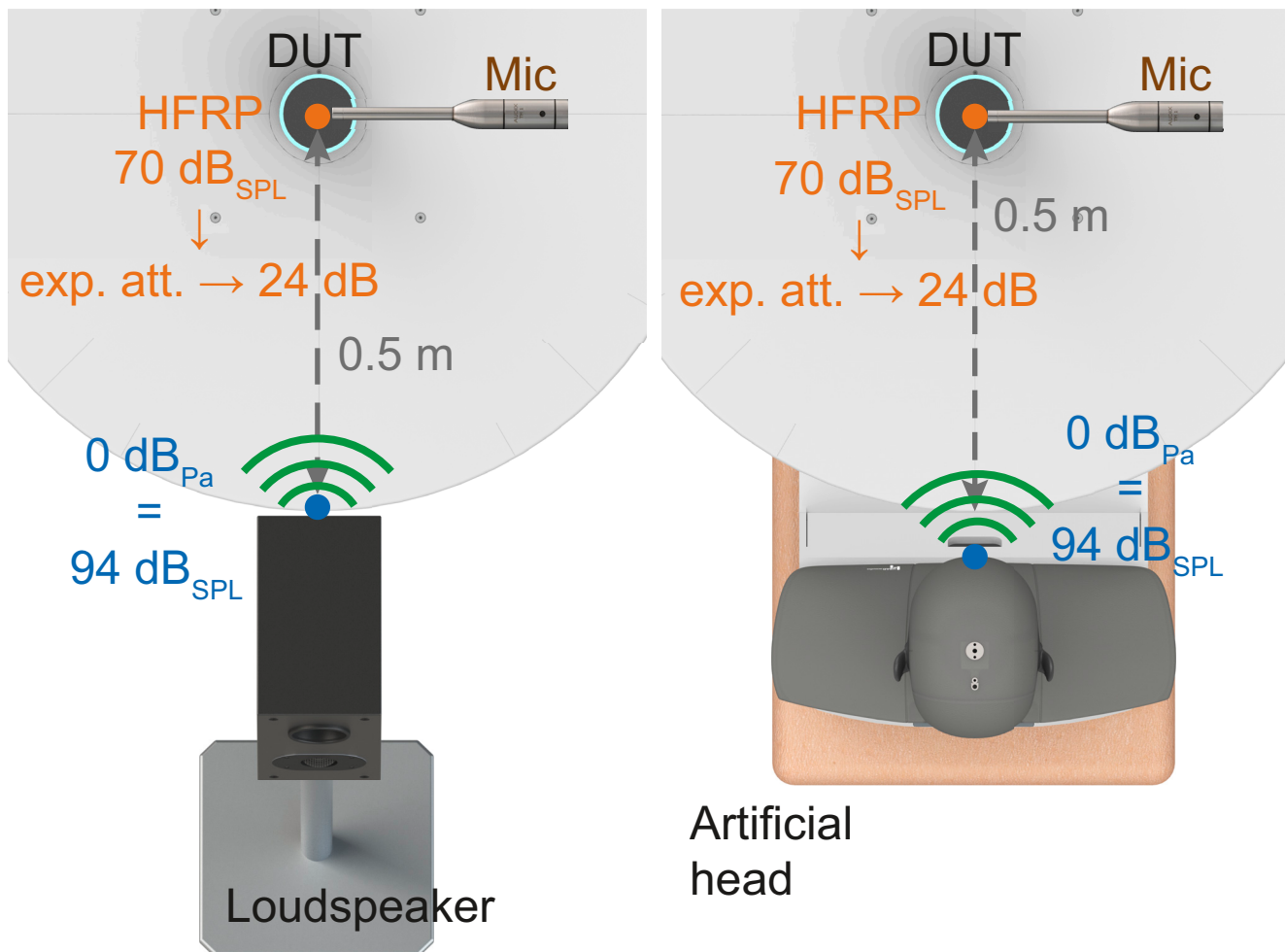

## 5.3 Preparation

- If necessary, run or repeat the microphone calibration. Refer to chapter 3.
- If necessary, run or repeat the loudspeaker equalization. Refer to chapter 4.
- Connect the equipment according to chapter 2.6.
- Start RME TotalMix FX.
- Start VoCAS.

## 5.4 HFRP calibration procedure

1. Go to RME TotalMix FX.
2. Select **Options** in the menu bar.
3. Select **Reset Mix**.
4. Select **Total Reset**.

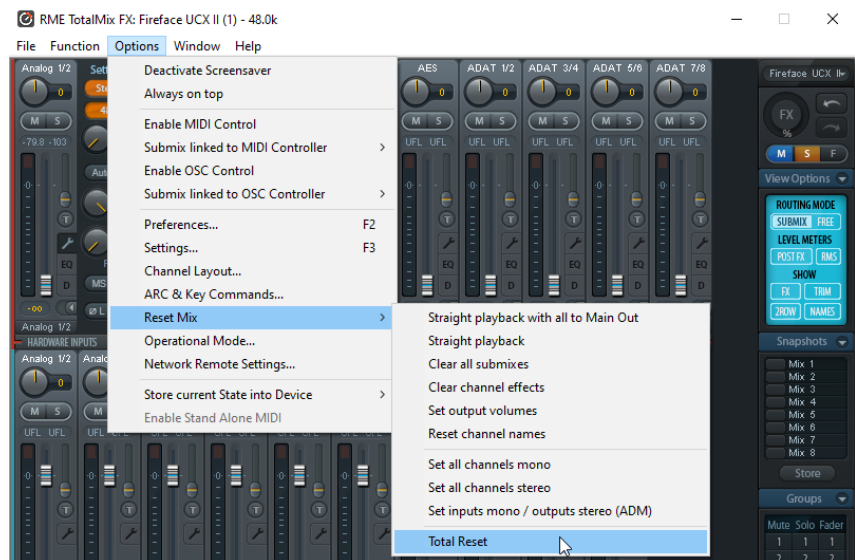

5. Enable phantom supply for the connected microphone. Select the button **48 V**. The color of the button changes to orange.



6. Go to VoCAS.
7. Select **File > VoCAS settings**.
8. Select **Extended > Setup configuration**.
9. Enable **Level Correction at DUT microphone**.
10. Select **Determine correction value**.

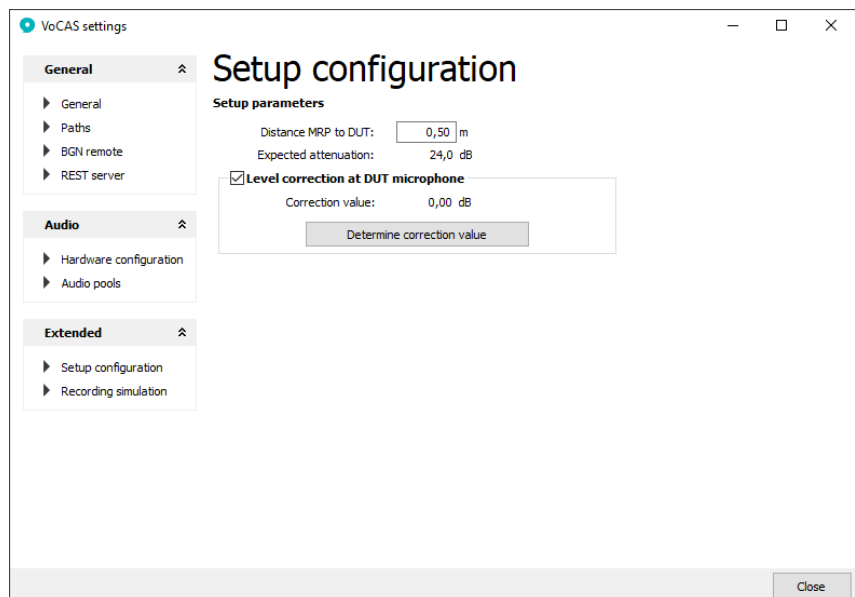

11. Select the appropriate loudspeaker equalization for the applied configuration from the drop-down list.
12. Select **OK**.

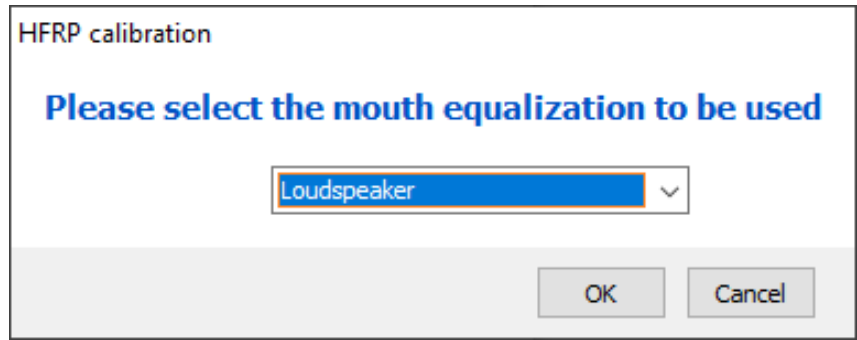

13. Select the appropriate microphone calibration.
14. Select **Next**.

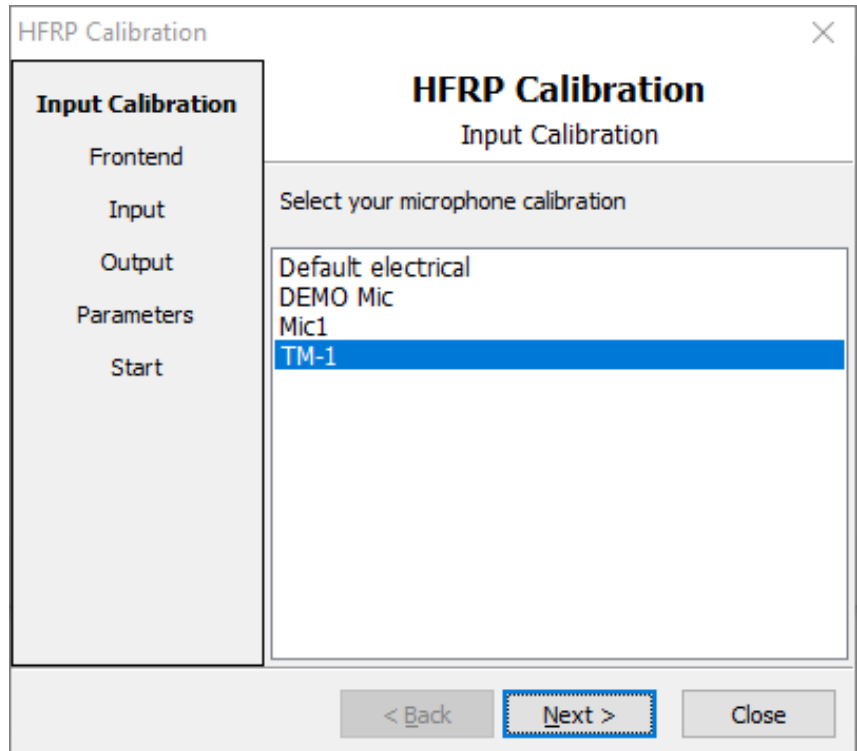

15. Select **Fireface UCX II**.
16. Select **Next**.

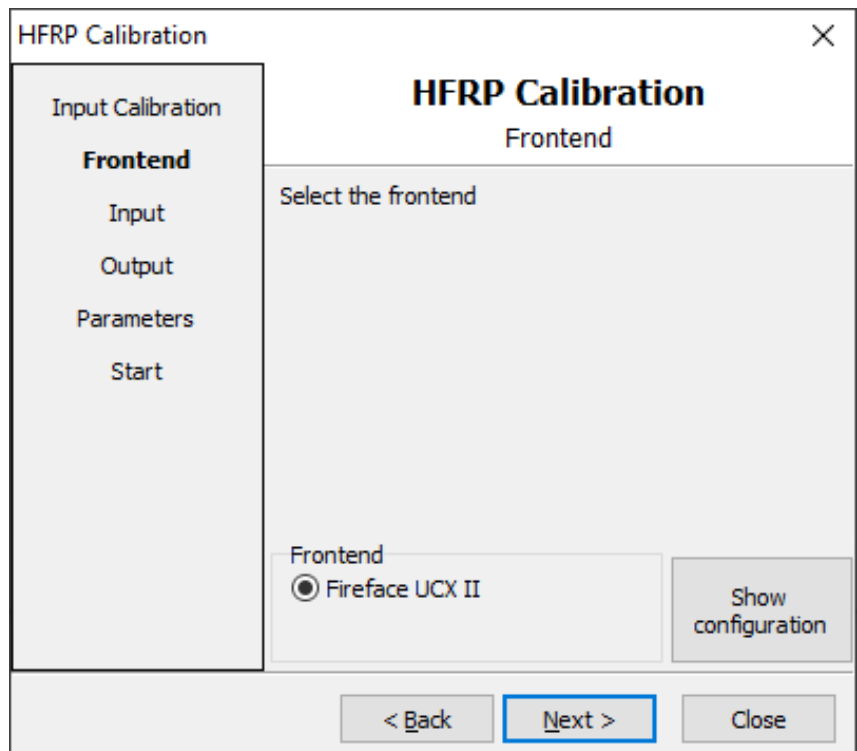

- 17. Select the applied input interface and the applied channel of the microphone.
- 18. Select **Next**.

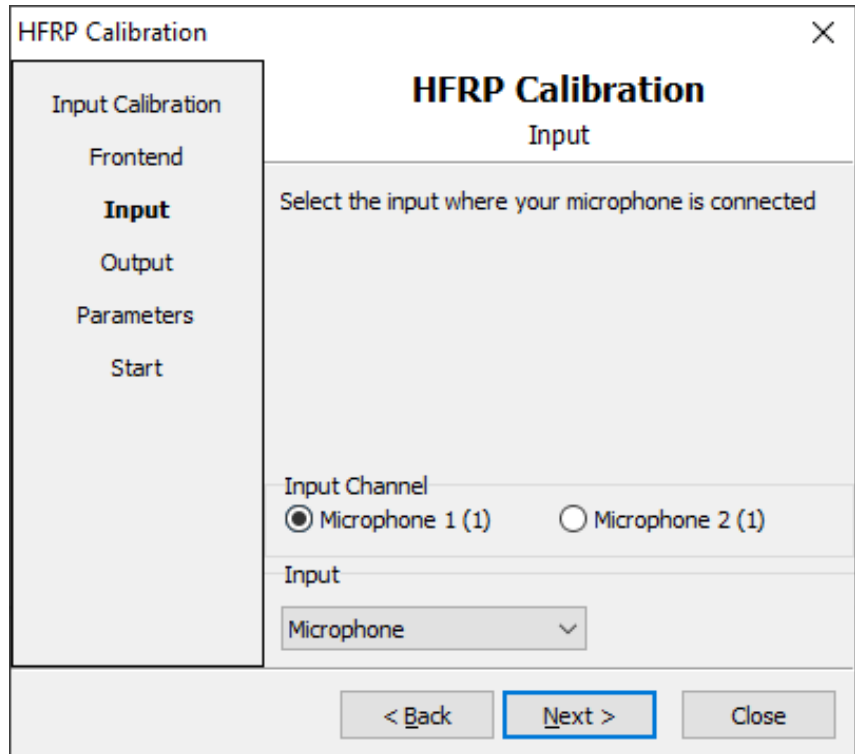

- 19. Select the applied output interface and the applied channel of the loudspeaker/artificial mouth.
- 20. Select **Next**.

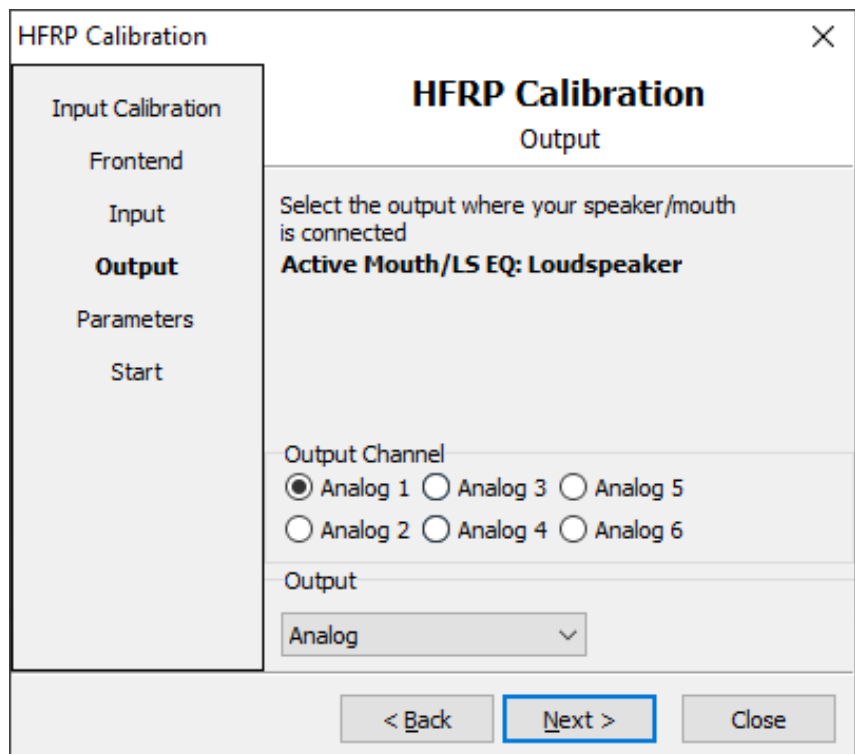

21. Enter/change the expected attenuation. It determines the deviation from the output level of the mouth/speaker and therefore the level at the HFRP.  
Two distances with common attenuations are provided (0.3 m, 0.5 m).
22. Enter the desired frequency range of the HFRP calibration.
23. Select **Next**.

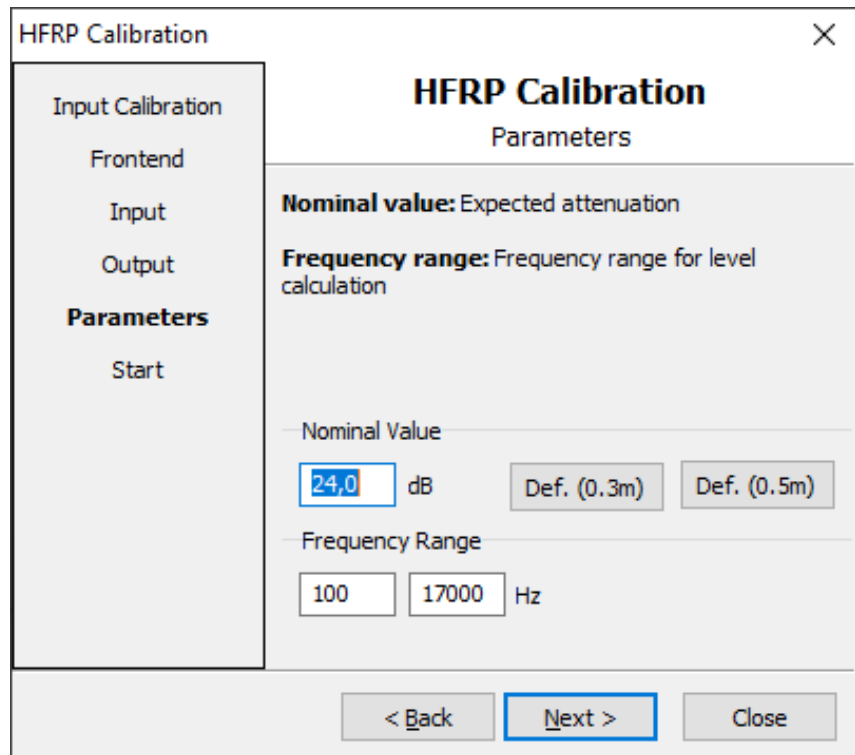

24. Check and confirm the settings for the equalization.
25. Select **Start** to execute the HFRP calibration.

If the deviation between nominal value/ expected attenuation and measured correction value is lower than 3 dB, VoCAS accepts and applies the correction value.

If the deviation between nominal value/ expected attenuation and measured correction value is higher than 3 dB, VoCAS displays a warning. However, this correction value can be accepted and applied manually.

