

Example of measurement result „Attenuation range during double talk“ in ACQUA analysis module ACQUAlyzer. Upper window: Time sequence of measured signal (green) and source signal (gray). Lower window: Level vs. time analysis of the measured signal referred to the source signal.

DESCRIPTION

The German Association of the Automotive Industry (VDA) has defined a specification regarding the speech quality of hands-free communication in vehicles. The requirements and test methods described in this specification have been co-developed by HEAD acoustics and are available in the currently valid version 1.6 for use with the communication analysis system ACQUA as measurement standard VDA-HFT.

In combination with ACQUA and the artificial head measurement system HMS II.3, VDA-HFT allows the automated analysis and experimental optimization of complete systems and subsystems for hands-free communication in vehicles.

VDA-HFT comprises numerous standard values such as loudness rating, transfer function, idle channel noise in sending and receiving direction, suppression of out-of-band signals, echo attenuation and minimum activation levels. In addition, VDA-HFT takes into account several other important aspects:

- Consideration of car type specific conditions by measuring the hands-free terminal in its original mounting state. For retrofit solutions: use of a car cabin with typical acoustic characteristics.
- Tests under silent conditions as well as with realistic background noise, acoustic driving simulation equalized to target car, consideration of different speeds, engines and car body styles.
- Artificial head measurement system as "user" of the hands-free terminal.
- Primary focus on conversation parameters such as double talk performance and quality of background noise transmission.

- Additional tests of Bluetooth® transmission of target mobile phone handsets
- Some of the measurements are based on current standards for third generation mobile phones such as 3GPP (3rd Generation Partnership Project), others on the results of auditory tests (another quality aspect of VDA-HFT compared to commonly used standards).

APPLICATIONS

- **Automated speech quality analysis** of car hands-free terminals
- **Experimental development and optimization** of car hands-free terminals with objective evaluation of sound quality
- **Optimized positioning** of hands-free microphones and loudspeakers in cars
- **Bluetooth® measurements of mobile phone handsets**

TEST SIGNALS

- Composite source signals (CSS)
- Artificial voice
- Activation sequences
- Special noise sequences
- Speech sequences
- CSS combinations for double talk simulation
- AM/FM modulated sine signals for echo measurements
- Background noise

DATA SHEET

VDA-HFT (Code 6770)

Measurement Standard

Speech Quality Assessment of Car Hands-free Terminals According to VDA Specification V1.6

Overview

The integration of hands-free systems in cars is a challenging topic. The arrangement of microphones and loudspeakers, the variety of background noise situations and additional artifacts due to RF problems significantly influence speech quality.

VDA-HFT is a test suite which implements version 1.6 of the car hands-free specification of the German Association of the Automotive Industry (VDA). Some methods described in this specification are based on other ITU recommendations and have been successfully adapted to the car environment. The test methods focus on

- **Standard telephometric requirements such as frequency responses and loudness ratings in single talk situations**
- **Echo performance and level variation in single and double talk situations**
- **Quality of background noise transmission**

VDA-HFT can be used by manufacturers and suppliers of the automotive industry to qualify and optimize complete hands-free systems as well as the subsystems of microphone, speakerphone and telephone with short-range wireless transmission link used to interconnect to the mobile network, e.g.:

- **Built-in hands-free systems**
- **After-market hands-free car kits**

MEASUREMENTS

The following list gives a summary of the measurements included in VDA-HFT:

Measurement Parameters and Requirements for Microphones

- Microphone Sensitivity in Anechoic Conditions / in the Car
- Microphone Distortion in Anechoic Environment / in the Car
- Microphone Frequency Response in the Car
- Idle Channel Noise
- Ambient Noise Rejection in the Car

Measurement Parameters and Requirements for Hands-free Terminals

- Delay in SND / RCV
- Loudness Rating in SND / RCV
- Frequency Response in SND / RCV
- One Way Speech Quality TOSQA in SND/RCV
- Idle Channel Noise in SND/RCV
- Discrimination Against Out-of-Band Signals in SND
- Spurious Out-of-Band Signals in RCV
- Acoustical Echo Terminal Coupling Loss (TCL_{eff})
- Echo Level vs. Time
- Spectral Echo Attenuation
- Switching Characteristics Activation in SND/RCV

- Attenuation Range in SND/RCV
- Double Talk Performance, type classification of hands-free terminals
- Attenuation Range in SND during Double Talk: $A_{H,S,dt}$
- Attenuation Range in RCV during Double Talk: $A_{H,R,dt}$
- Detection of Echo Components during Double Talk
- Background Noise Transmission, D Value
- Background Noise Transmission after Call Setup, Ambient Noise Rejection
- Quality of Background Noise Transmission with Far End Speech / with Near End Speech
- "Comfort Noise" Injection

Verification of the Transmission Performance of Short Range Wireless (SRW) Transmission Enabled Phones

- Delay in SND/ RCV
- Junction Loudness Rating in SND/ RCV
- Linearity in SND/ RCV
- SND/ RCV Sensitivity Freq. Response
- Noise Cancellation Test in SND
- Speech Quality during Single Talk
- One Way Speech Quality TOSQA SND/RCV; alternatively:
 - One Way Speech Quality PESQ SND/ RCV
- Verification of Disabled Echo Control

Informative Measurements (Optional)

- Quality of Background Noise Transmission (with near End Speech) (pause variation)
- Real Speech measurement Single Talk, Double Talk
- 3Quest - 3-fold Quality Evaluation of Speech in Telecommunications (BGN)
- SRW Junction Loudness Rating P.50 SND/ RCV
- SRW Linearity P.50 SND/ RCV
- SRW AGC Test in SND/ RCV
- SRW Switched Level in SND/ RCV
- SRW Attenuation Range in SND/ RCV during Double Talk
- SRW Verification of Disabled Echo Control P.50
- SRW Quality Pie

Note: A separate project has been added to support the use of MFE XI instead of a radio tester and a mobile phone. This test setup for hands-free terminals is not mandatory for standard-compliant testing but useful for R&D purposes.

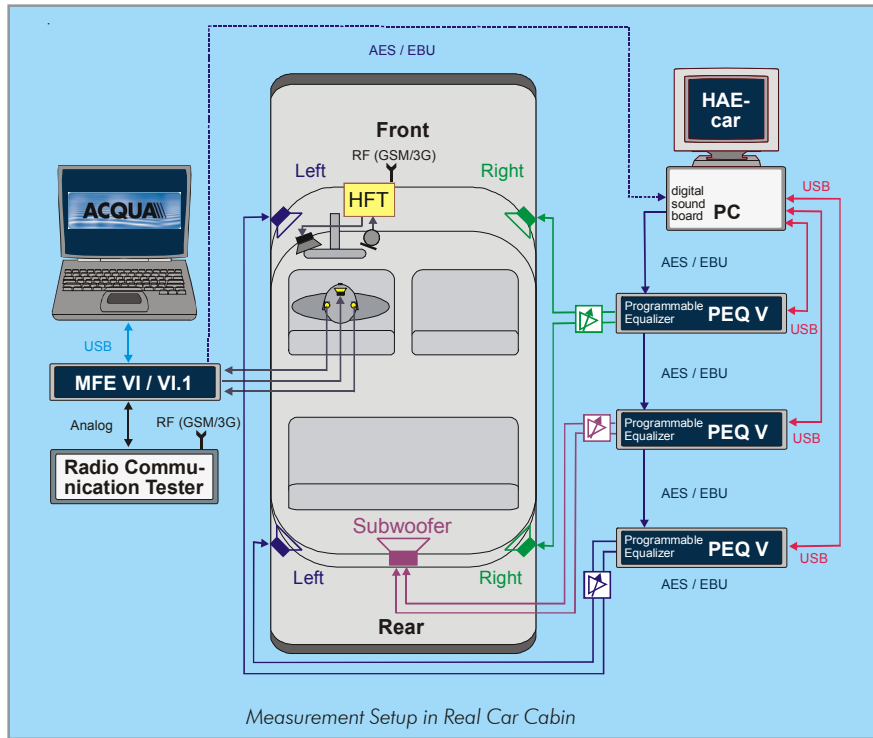

SYSTEM REQUIREMENTS

VDA-HFT requires the following system components:

- **ACQUA** Communication Analysis System as one of the following versions (version 2.5.100 or later):
 - Full-license (Code 6810)
 - Workplace (Code 6830, for post-analysis and documentation only)
 - Compact Systems (Code 6860.xx)
- **ACOPT 10**: TOSQA2001, Telecommunications Objective Speech Quality Assessment (Code 6820)
- **ACOPT 17**: Relative Approach (Code 6839)
- **HMS II.3-33 or II.3-34** HEAD Measurement System (Code 1230.1 or 1230.2). Alternatively: HMS II.6 (Code 1389)
- **MFE VI.1** Measurement Frontend (Code 6462) with Option **MFEVI-BEQ** (Code 6461)
- **MFE XI** Universal Bluetooth® Access Point (Code 6482). Note: only required for Bluetooth® measurements
- **Background Noise Simulation System**, e.g. **HAE-car** (Code 6970)
- **GSM/3G Radio Communication Tester** with appropriate narrowband speech codec (not provided by HEAD acoustics)

OPTIONS

- **UG-VDA** Upgrade from HQS-HFT to VDA-HFT (Code 6771)
- **ACOPT 16**: PESQ, Perceptual Evaluation of Speech Quality (Code 6836). Note: only required for SRW measurements (e.g. Bluetooth®).
- **ACOPT 20**: Quality Pie (Code 6843)
- **ACOPT 21**: 3QUEST, 3-fold Quality Evaluation of Speech in Telecommunications (Code 6844)

DELIVERY ITEMS

- **VDA-HFT** Measurement standard, delivered as ACQUA database on CD (Code 6770)
- **Keyfile** (for ACQUA 2.5.100) or **V2C file** (for ACQUA 3.0.100 or later) on CD
- **Manual** as PDF on CD

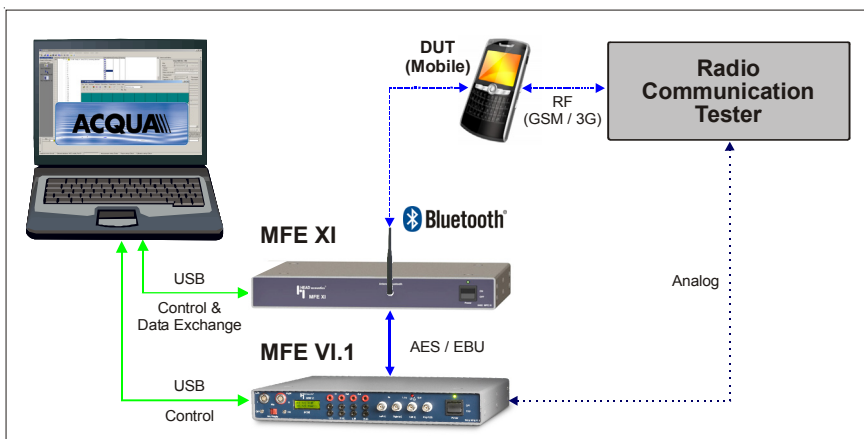

Example configuration: Bluetooth® mobile phone tests with ACQUA, MFE VI.1, MFE XI, Radio Communication Tester

The Bluetooth® word mark and logos are registered trademarks owned by Bluetooth SIG, Inc. and any use of such marks by HEAD acoustics GmbH is under license. Other trademarks and trade names are those of their respective owners.

