

ViBRIDGE



Code 1703.3

HMS II.3 ViBRIDGE

Head Measurement System, Low-Noise, with Human-like ViBRIDGE Ear Simulators (Left and Right) and Artificial Mouth

OVERVIEW

HMS II.3 ViBRIDGE

Code 1703.3

Head Measurement System, Low-Noise Version, with Human-like ViBRIDGE Ear Simulators (left and right) and Artificial Mouth

HMS II.3 ViBRIDGE is an artificial head with an artificial mouth and two low-noise ear simulators with human-like ear canals and bone conduction speech simulation. The system is ideally suited for measuring intra-concha and insert-type devices that utilize bone conduction.

The occluded ear simulators comply with recommendation ITU-T P.57. Accordingly, the anatomically shaped pinnae are compliant with the type 4.4 pinna simulator according to recommendation ITU-T P.57. Both pinnae carry precision electro-mechanic actuators to simulate bone-conducted near-end speech to any intra-concha device. The very low self-noise level allows conclusive measurements even below the hearing threshold. Combined with a very high upper limit, HMS II.3 ViBRIDGE is ideally suited for all measurements in telecommunication and beyond.

The artificial mouth of HMS II.3 ViBRIDGE is a two-way loudspeaker design and complies with the requirements from recommendation ITU-T P.58. It is capable of reproducing the full spectrum of human voice with lowest distortion, allowing high-quality measurements.

KEY FEATURES

Geometric and acoustic characteristics according to recommendation ITU-T P.58

Modular design for easy retrofitting with compatible components

Ear simulators:

- › Electro-mechanic actuators to simulate bone-conducted near-end speech
- › Anatomically shaped pinnae with human-like ear canals and right ear simulator
- › High sensitivity condenser microphone with very low inherent noise floor and high upper limit
- › Compliant occluded ear simulator according to recommendation ITU-T P.57
- › Compliant with type 4.4 pinna simulator according to recommendation ITU-T P.57
- › TEDS support (IEEE 1451.4 class MMI)

Artificial mouth:

- › Low-distortion two-way design with very wide frequency range (up to fullband)
- › Acoustic characteristics according to recommendation ITU-T P.58
- › Digital equalization with ACQUA

APPLICATIONS

Comprehensive testing of in-ear headsets utilizing bone conduction for evaluating and improving their voice pickup

DETAILS

HMS II.3 ViBRIDGE is an artificial head which is ideally suited for testing of in-ear headsets that utilize structure-borne sound. It comprises two artificial ears with human-like ear canals and simulation of structure-borne sound for voice pickup, as well as an artificial mouth. Complying with the geometric and acoustic characteristics of recommendations ITU-T P.57 and ITU-T P.58, HMS II.3 ViBRIDGE is appropriate for close-to-the-ear but also arbitrary far-field measurement scenarios. It can be used to test transducers and signal processing of, e.g., handsets, headsets, headphones, hands-free devices, voice-operated equipment, hearing protectors, and more.

Ear Simulator and ViBRIDGE Pinnae

The pinnae and the ear simulators of HMS II.3 ViBRIDGE accurately replicate the anatomy and the performance of the human outer ear. For standard-compliant measurements, the occluded ear simulators and the type 4.4 pinnae comply with recommendation ITU-T P.57. The built-in microphone capsules provide a very low inherent noise floor and have a high sound pressure level limit. As such, it is qualified for any measurement with signal levels below the human hearing threshold as well as for measurements with high levels. Precision electro-mechanic actuators simulate structure-borne sound which can be picked up by appropriate intra-concha headsets.

Artificial Mouth

The artificial mouth of HMS II.3 ViBRIDGE is fully compliant with recommendation ITU-T P.58. It realistically reproduces the acoustic behavior of a talking person. The two-way loudspeaker design provides an excellent frequency response. The wide frequency range makes it ideally suited for measurements in super-wideband and fullband applications. The artificial mouth is optimized for use with the optional *coreOUT-Amp2* hardware board from the *labCORE* hardware platform.

Playback and Recording

For recordings, HMS II.3 ViBRIDGE connects to the ACQUA communication analysis system via the *labCORE* hardware platform equipped with the optional *coreIN-Mic4* hardware board. The software extension *coreBEQ* for *labCORE* provides equalization of binaural acoustical signals for recordings with HMS II.3 ViBRIDGE.

The artificial mouth of HMS II.3 ViBRIDGE is powered by the optional *coreOUT-Amp2* hardware board from *labCORE*. ACQUA supports comfortable and precise equalization of the mouth..



HMS II.3 ViBRIDGE mounted on the HTB VI torso box

Modularity

The modular design of the artificial ear enables adding or changing ear simulator(s) and pinnae quickly. This facilitates the interchangeability with either the ear simulator of the standard variant HMS II.3 (with pinna type 3.3) or the low-noise ear simulator with straight ear canal of HMS II.3 LN (with pinna type 3.3). HMS II.3 ViBRIDGE includes TEDS (Transducer Electronic Data Sheet) technology that enables ACQUA to determine the type and serial number of the ear simulators, as well as HMS II.3 ViBRIDGE itself.

Accessories

For measurements of telephony handsets, HMS II.3 ViBRIDGE is expandable by the optional handset positioners HHP IV or HHP III.1. Both provide precise positioning of any handset as well as precise adjustment of application force from the handset to the pinna.

Another accessory is the AN HMS artificial nose. It makes measurements of nose-supported device e.g., AR/VR glasses and headsets, more reproducible and convenient to set up.

HMS II.3 ViBRIDGE has a mounting plate on top for attaching MSA I/MSA II. MSA I/MSA II are microphone surround arrays for recording customized background noises and for an equalized playback via 3PASS. Furthermore, the mounting plate provides fixation for the TLP II triaxial laser pointer for precise alignment of HMS II.3 ViBRIDGE.

The HTB VI torso box simulates a human torso. It is included in the scope of supply by default. HMS II.3 ViBRIDGE mounted on HTB VI forms a head and torso simulator (HATS) according to recommendation ITU-T P.58. The bottom plate of HMS II.3 ViBRIDGE provides a Camlock coupling for convenient mounting on HTB VI.

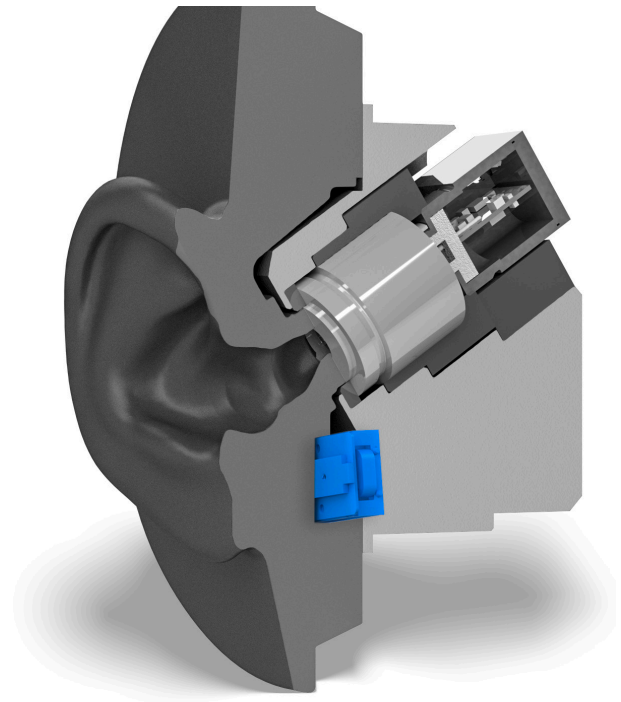

A cut through the right ear simulator of HMS II.3 ViBRIDGE. The human-like ear canal leads to the acoustic coupler that contains a high-quality condenser microphone. The microphone covers a very wide dynamic range from below the human hearing threshold up to 148 dB_{SPL}.

The ViBRIDGE precision actuator (highlighted in blue) generates vibrations to simulate structure-borne near-end speech accurately for inserted devices.

TECHNICAL DATA

Artificial Ear

Frequency range	3 Hz – 20000 Hz
Frequency responses (FF/DF)	Compliant with ITU-T P.58
Directivity characteristics	Compliant with ITU-T P.58
Transfer impedance	Compliant with IEC 60318-4 and ITU-T P.57
Dynamic range	16 dB(A) _{SPL} – 148 dB _{SPL}
Self-noise	Compliant with ITU-T P.57
Microphone sensitivity	50 mV/Pa
Polarization voltage	200 V
Supply voltages	
› U (recommended)	› ± 60 V
› U (possible)	› + 120 V

ViBRIDGE

Transducer type	Variable-reluctance suspended plate actuator
Transducer frequency range	approx. 80 Hz – 19000 Hz
Transducer impedance	8 Ω
Power handling	typ. 1 W (integrated protection allows higher short-term power)
Excursion alignment axis	Parallel to ear canal center line according to recommendation ITU-T P.57
Bone conduction simulation Matched to human data measured with accelerometer Vesper VA1200	approx. 80 Hz – 1200 Hz (currently used)

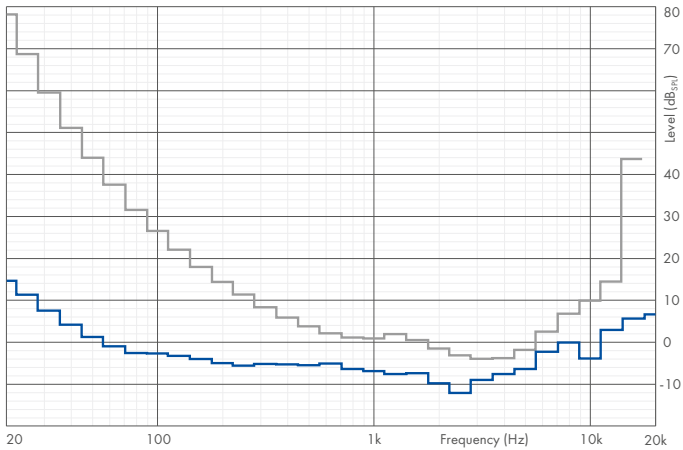

Typical self-noise of HMS II.3 ViBRIDGE ear simulators (—) vs. average human hearing threshold (---)

All curves diffuse-field equalized, HMS II.3 ViBRIDGE measured with 4096 FFT, average hearing threshold according to ISO 389-7

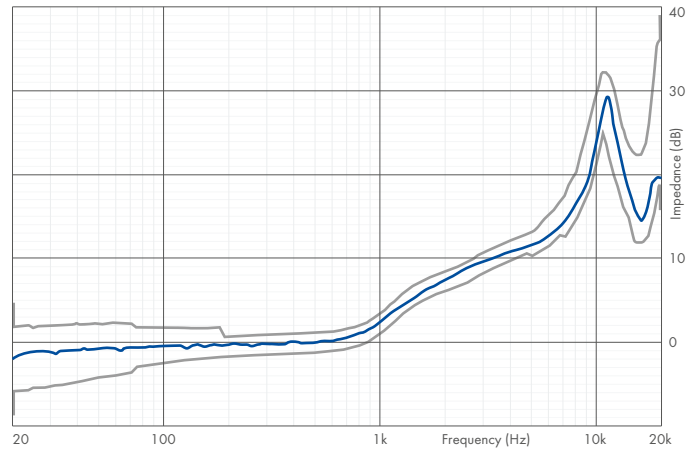

Typical transfer impedance of HMS II.3 ViBRIDGE ear simulator (—) vs. ITU-T P.57 tolerance scheme (---)

Curve and tolerance scheme normalized to 500 Hz

Artificial Mouth

Loudspeaker configuration	2-way
Impedance	4 Ω
Frequency range	<ul style="list-style-type: none"> › Unequalized › Equalized
Power handling	<ul style="list-style-type: none"> › P (continuous) › P (short-term)
Total Harmonic Distortion (THD)	<ul style="list-style-type: none"> › at 0 dB_{PA} (94 dB_{SPL}) › at 6 dB_{PA} (100 dB_{SPL}) › at 12 dB_{PA} (106 dB_{SPL}) › at 18 dB_{PA} (112 dB_{SPL})
Max. continuous output level	<ul style="list-style-type: none"> › Pink noise › Sine › Real speech according to recommendation ITU-T P.501
	<p>at Mouth reference Point (MRP), equalized, with coreOUT-Amp2</p> <ul style="list-style-type: none"> › 100 Hz – 20000 Hz (± 4 dB) › 50 Hz – 20000 Hz (± 1 dB), exceeds ETSI TS 102 924 › 20 W › 50 W (max. power is electrically limited > 6 kHz) › < 4% (100 Hz), < 0.5% (200 Hz – 20000 Hz), exceeds recommendation ITU-T P.58 › < 6% (100 Hz), < 1% (200 Hz – 20000 Hz) › < 10% (100 Hz), < 2% (200 Hz – 20000 Hz) › < 3% (200 Hz – 20000 Hz) › at MRP, equalized, with coreOUT-Amp2 › min. 112 dB_{SPL} (50 Hz – 16000 Hz), min. 106 dB_{SPL} (20 Hz – 20000 Hz) › min. 112 dB_{SPL} (200 Hz – 6000 Hz) at THD < 3%, min. 106 dB_{SPL} (100 Hz – 10000 Hz) at THD < 10% › No audible distortion up to approx. 110 dB_{SPL}

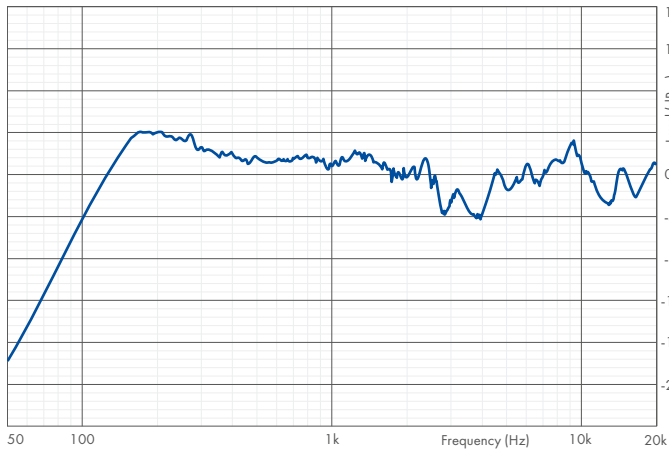

Typical frequency response of unequalized two-way mouth (—)

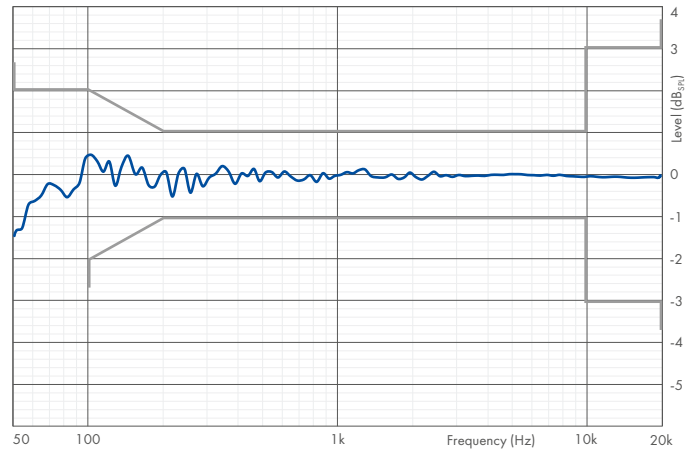

Typical frequency response of equalized two-way mouth (—) vs. ETSI TS 102 924 tolerance scheme (—)

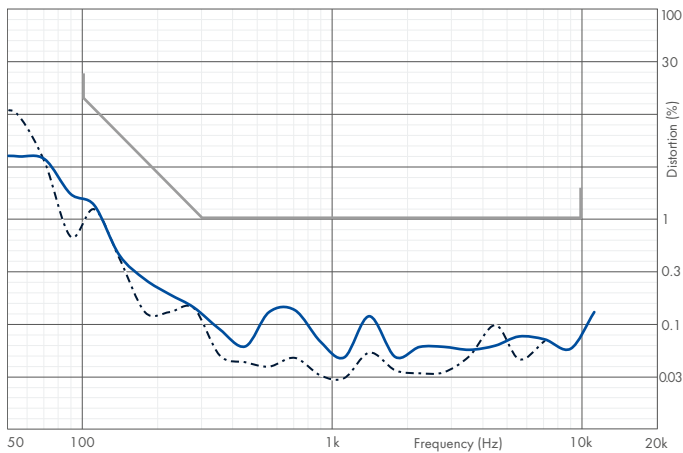

2nd (—) and 3rd (---) order harmonic distortion of equalized two-way mouth at 0 dB_{Pa} vs. recommendation ITU-T P.58 tolerance scheme (—)

Other

Dimensions and Weight	
Overall dimensions (Width × Height × Depth)	460 mm × 400 mm × 210 mm 460 mm × 790 mm × 400 mm mounted on HTB VI
Weight	Approx. 6.8 kg (standard scope of delivery) Approx. 14.8 kg mounted on HTB VI
Environmental Conditions	
Operating temperature range	0 °C – 50 °C (32 °F – 122 °F)
Storage temperature range	-20 °C – 70 °C (-4 °F – 158 °F)
Humidity	20% – 80% relative humidity (non-condensing environment)

FEATURES

MSA I/MSA II

A centrally embedded thread at the top of HMS holds top-mounted accessories such as the microphone arrays MSA I, MSA II (shown), or the TLP II Triaxial Laser Pointer.



IMPEDANCE SIMULATOR AND VIBRIDGE PINNA

The anatomically shaped pinna of HMS II.3 ViBRIDGE replicates the geometry of a human auricle and outer ear canal. Behind the pinna, the impedance simulator HIS R LN HEC (shown) simulates the ear's acoustic properties.

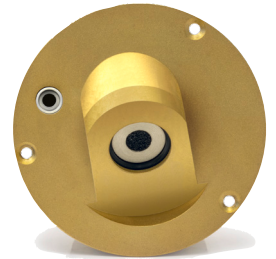

ViBRIDGE PINS

Pin contacts for supplying and controlling the ViBRIDGE actuator of HEL/HER 4.4 ViBRIDGE (-V1).



ARTIFICIAL MOUTH AND ARTIFICIAL NOSE

The two-way loudspeaker design of the artificial mouth provides excellent frequency coverage, a high maximum SPL, and very low distortion.

The optional AN HMS artificial nose can be fixed at the facial crosshair of HMS II.3 ViBRIDGE.



BOTTOM PLATE

The bottom plate provides a speakON connector for the artificial mouth and the ViBRIDGE actuator, and two 7-pin LEMO connectors for left and right ear simulator.

A quick-clamping mechanism enables easy and fast attaching of HMS II.3 ViBRIDGE to the HTB VI torso box. The thread below allows to fasten HMS on, e.g., the optional HMT III tripod.



MICROPHONE HOLDER

A snap lock at the throat can accommodate the delivered microphone mount for calibration of the mouth. Durable rubber rings can accommodate optional microphones of different sizes.

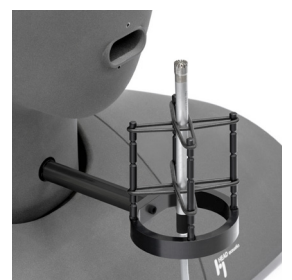

EAR SIMULATOR AND PINNA OPTIONS

By default, HMS II.3 ViBRIDGE has a left and right pinna type 4.4 and a right ear impedance simulator for monaural measurements. It is expandable by a left ear impedance simulator for binaural testing. The modular design of the HMS II Series enables to build numerous different configurations optimized for specific purposes



HMS II.3

- › Impedance simulator with straight ear canal
- › Anatomically shaped pinna type 3.3 with straight ear canal



HMS II.3 LN

- › Low-noise impedance simulator with straight ear canal
- › Anatomically shaped pinna type 3.3 with straight ear canal



HMS II.3 LN HEC

- › Low-noise impedance simulator with human-like ear canal
- › Anatomically shaped pinna type 4.4 with human-like ear canal

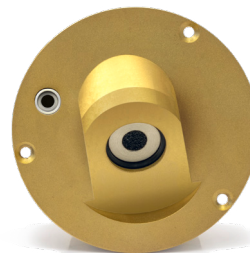

FURTHER HMS II MODELS

Further specific versions of the HMS II Series are available.

HMS II.4

- › Anatomically shaped pinnae type 3.3
- › Right ear impedance simulator
- › Ear retrofitting options
- › No artificial mouth (not retrofittable)



HMS II.5

- › Anatomically shaped pinnae type 3.3
- › No impedance simulators
- › Ear retrofitting options
- › Artificial mouth



HMS II.6/7

- › Left and right free-field microphones and impedance converter
- › Simplified pinnae
- › HMS II.6 has condenser microphones
- › HMS II.7 has IEPE/ICP® microphones
- › Artificial mouth



OPTIONS

General

coreBEQ (Code 7740)

- › labCORE binaural equalization, incl. filter set for one artificial head

coreBEQ-Add (Code 7741)

- › labCORE binaural equalization, additional set of filters for one artificial head (coreBEQ required)

SCOPE OF DELIVERY

HMS II.3 ViBRIDGE (Code 1703.3)

- › HEAD measurement system, low-noise, with human-like ViBRIDGE ear simulators (left and right) and artificial mouth

HIS L LN HEC (Code 1701.2)

- › Head Impedance Simulator, left, low-noise, for HMS II.3/4/5, human ear canal version

HIS R LN HEC (Code 1702.2)

- › Head Impedance Simulator, right, low-noise, for HMS II.3/4/5, human ear canal version

HEL 4.4 ViBRIDGE (Code 1717)

- › Flexible pinna for HMS II.3/5, left ear, according to ITU-T P.57 Type 4.4, ViBRIDGE version

HER 4.4 ViBRIDGE (Code 1718)

- › Flexible pinna for HMS II.3/5, right ear, according to ITU-T P.57 Type 4.4, ViBRIDGE version

CLL-L I.3 (Code 1721-3)

- › Cable LEMO 7-pin male <> LEMO 7-pin male, black, 2.95 m

CLL-R I.3 (Code 1722-3)

- › Cable LEMO 7-pin male <> LEMO 7-pin male, red, 2.95 m

CSS V.3 (Code 1723-3)

- › Cable speakON plug <> speakON plug, 2.95 m

CSB II (Code 9849)

- › Adapter speakON male <> Banana plug

HTB VI (Code 1574)

- › HEAD Torso Box for HMS II/III/IV and HSU HCC-HMS (Code 1741)

- › Carrying case for accessory parts HMS II.x containing:

- » Mic-pos (Code 1731)
 - Microphone positioner for HMS II.3/5/6/7
- » LR-MRP (Code 1626)
 - Lip ring and MRP pointer
- » HCA HMS II.x (Code 1733)
 - Microphone calibration adapter for HMS II.3/4, circular
- » AK HMS II.x (Code 1734)
 - Allen key 2.5 mm for pinna, nose, and impedance simulator mounting of HMS II.x
- » 3 × socket screw M3 × 6 for assembling HIS types (spare parts)
- » 2 × Throat blind cap (spare parts)

Manual

AN HMS (Code 1418)

- › Extension for HEAD Measurement System HMS: Artificial nose

UG HMS/HSU move°S (Code 1750)

- › Upgrade HMS/HSU to move°S, motorized head turning version

HSM V (Code 1520)

- › HEAD Seat Mount adapter for artificial head measurement systems or a head-shoulder unit

HSC V-V2 (Code 1525-V2)

- › Carrying case for HMS II.x

HMT III (Code 1961)

- › Height-adjustable tripod for Head Measurement System

SB HRT (Code 6501)

- › Stand base for mounting HMS II.x on HRT I

TLP II (Code 1969)

- › Triaxial Laser Pointer for HMS/HSU positioning

Ear Simulator Retrofitting

Delivery of left impedance simulators includes the cable LEMO 7-pin male <> LEMO 7-pin male, black, 2.95 m (Code 1721-3)

HIS L (Code 1701)

- › Head Impedance Simulator, left, for HMS II.3/4/5

HIS L LN (Code 1701.1)

- › Head Impedance Simulator, left, low-noise version, for HMS II.3/4/5

HIS R (Code 1702)

- › Head Impedance Simulator, right, for HMS II.3/4/5

HIS R LN (Code 1702.1)

- › Head Impedance Simulator, right, low-noise version, for HMS II.3/4/5

GENERAL REQUIREMENTS

Hardware

labCORE (Code 7700)

- › Modular multi-channel hardware platform
- coreBUS (Code 7710)
- › labCORE I/O bus mainboard
- coreOUT-Amp2 (Code 7720)
- › labCORE power amplifier board
- coreIN-Mic4 (Code 7730)
- › labCORE microphone input board

Software

One of the following software applications:

ACQUA (Code 6810)

- › Advanced Communication Quality Analysis Software, Full license version

ACQUA Compact (Code 6860)

- › Compact test system

RC-labCORE (Code 6984)

- › Remote configuration software for labCORE

VoCAS (Code 7970)

- › Voice Control Analysis System



Type 4.4 pinnae are available in the colors dark gray and light gray. The light gray pinnae are available for retrofitting or initial delivery with HMS II.3 ViBRIDGE.

Pinna Retrofitting

HEL 3.3 (Code 1711)

- › Flexible pinna for HMS II.3/4/5, left ear, according to ITU-T P.57 type 3.3

HER 3.3 (Code 1712)

- › Flexible pinna for HMS II.3/4/5, right ear, according to ITU-T P.57 type 3.3

HEL 4.4 (Code 1715)

- › Flexible pinna for HMS II.3/4/5, left ear, according to ITU-T P.57 type 4.4

HER 4.4 (Code 1716)

- › Flexible pinna for HMS II.3/4/5, right ear, according to ITU-T P.57 type 4.4

HEL 4.4-V1 (Code 1715-V1)

- › Flexible pinna for HMS II.3/4/5, left ear, according to ITU-T P.57 type 4.4, gray color

HER 4.4-V1 (Code 1716-V1)

- › Flexible pinna for HMS II.3/4/5, right ear, according to ITU-T P.57 type 4.4, gray color

HEL 4.4 ViBRIDGE-V1 (Code 1717-V1)

- › Flexible pinna for HMS II.3/5, left ear, gray color, according to ITU-T P.57 type 4.4, ViBRIDGE Version

HER 4.4 ViBRIDGE-V1 (Code 1718-V1)

- › Flexible pinna for HMS II.3/5, right ear, gray color, according to ITU-T P.57 type 4.4, ViBRIDGE Version

Compatibility of Pinnae and Ear Simulators

Pinna type \ Impedance simulator	HEL 3.3	HER 3.3	HEL 4.4	HER 4.4	HEL 4.4-V1	HER 4.4-V1	HEL 4.4 ViBRIDGE	HER 4.4 ViBRIDGE	HEL 4.4 ViBRIDGE-V1	HER 4.4 ViBRIDGE-V1
HIS L	•									
HIS R		•								
HIS L LN	•									
HIS R LN		•								
HIS L LN HEC			•		•		•		•	
HIS R LN HEC				•		•		•		•

IN PRACTICE

APPLICATION EXAMPLE

Measurement of an In-Ear Headset Utilizing Bone-Conduction

This exemplary test scenario depicts testing an in-ear headset that utilizes bone-conducted sound to improve speech quality in sending direction with HMS II.3 ViBRIDGE. *labCORE* powers the artificial mouth as well as the ViBRIDGE actuators with the two amplified channels of *coreOUT-Amp2*. The ear simulators of HMS II.3 ViBRIDGE are connected to *coreIN-Mic4*. Background noise is simulated with 3PASS lab. For full repeatability of measurements, background noise playback is synchronized by *labCORE* through a pulse connection to the *labBGN* hardware platform. ACQUA operates in conjunction with *labCORE* to generate, receive, and analyze signals.

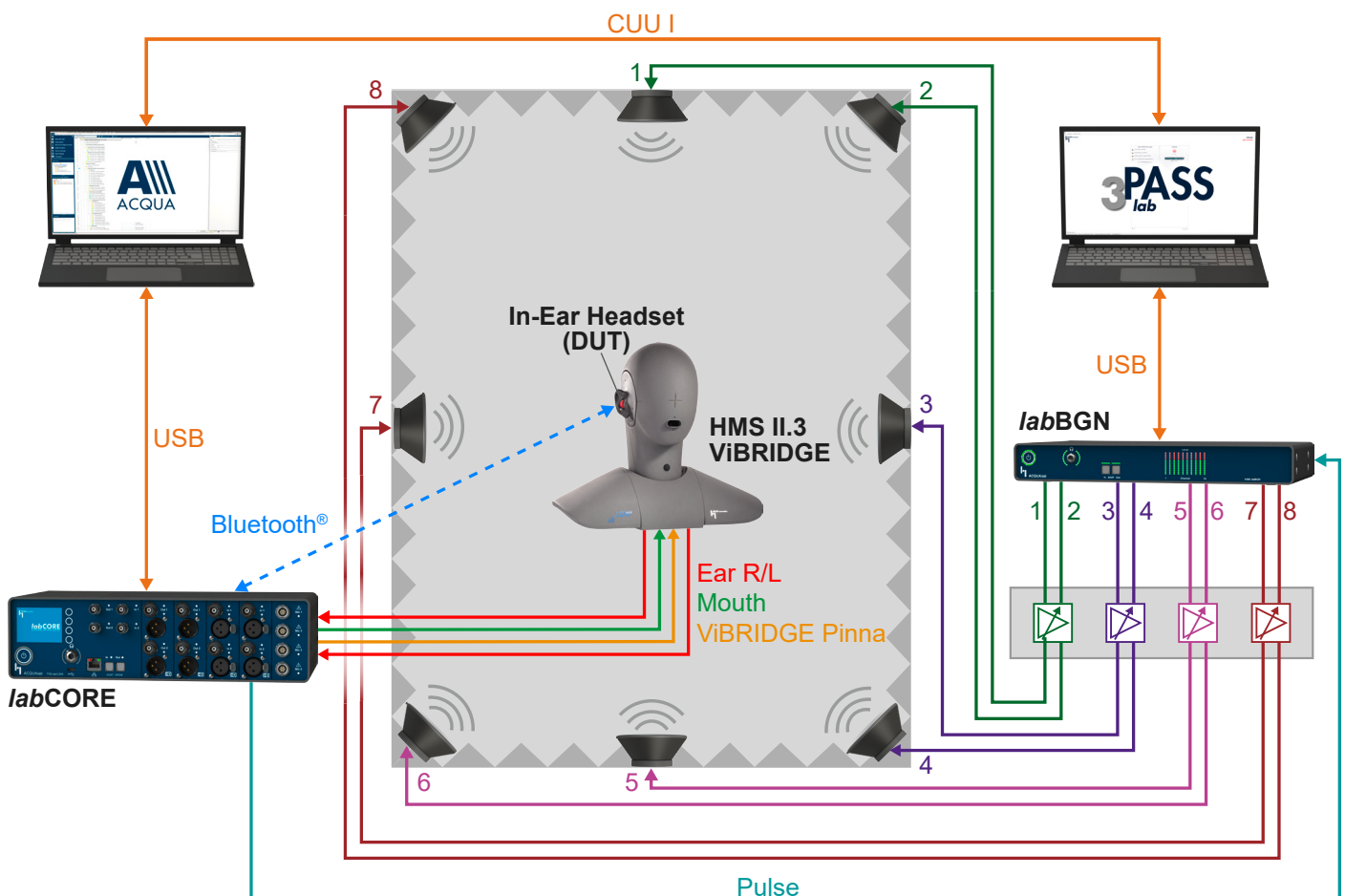

The Bluetooth® word mark and logos are registered trademarks owned by Bluetooth SIG, Inc. and any use of such marks by HEAD acoustics GmbH is under license. Other trademarks and trade names are those of their respective owners.

ICP® is a registered trademark of PCB Group, Inc.

speakON® is a registered trademark of Neutrik AG.

LEMO® is a registered trademark of LEMO S.A.

IEPE denotes an industry standard for piezoelectric sensors with integrated impedance-converting electronics. Comparable technologies are marketed by individual manufacturers under proprietary names such as ICP, CCLD, IsoTron, or DeltaTron. In this document, the term IEPE/ICP is used as a generic designation representing the corresponding manufacturer-specific product and trademark names



Contact Information

Ebertstraße 30a

52134 Herzogenrath, Germany

Phone: +49 2407 577-0

E-Mail: sales@head-acoustics.com

Website: www.head-acoustics.com